

Newly designed SQ-series pumps, now lighter and easier to carry!

SQ



SQA

Automatic model



SQ/SQA SERIES

The SQ/SQA-series are submersible portable stainless steel corrosion-resistant pumps with vortex impellers. They are made of 304/316 stainless steel, Nitrile Butadiene Rubber and special resin to stand up to rust and corrosion, and sport a new structural design that makes them even lighter and easier to carry than before.

Both pumps feature a top discharge, flow-thru design with forced motor cooling that enables extended running at low water level. In addition to that, the SQ-series has a slim body that fits inside 8-inch pipe.

The SQA-series is an automatic model with two simple float switches that prevents dry-running and reduces power consumption.

Though compact in size, these pumps come packed with a number of original technologies developed and honed over years of service, including an anti-wicking cable, dual inside mechanical seals with silicon carbide face and an Oil Lifter. Moreover, liquid paraffin is used as a lubricant, so the pumps can be used in food and aquaculture applications. Designed and built for sound quality and continuous duty, Tsurumi's SQ/SQA-series pumps are highly reliable, durable and assuredly meet the needs of users who cannot afford rusting.

Features

1 Anti-wicking Cable Entry

Prevents water incursion due to capillary action should the cable sheath be damaged or the end of cable submerged. Also prevents moist air from infiltrating the motor housing and condensation from forming inside the housing due to temperature differences between the housing and outside air.

2 Motor Protector

Reacts to excessive heat caused by overcurrent or dry-running to protect pumps. It not only cuts off the motor circuit automatically but also resets by itself. When the motor cools down to a safe operating temperature, the motor restarts.

3 Dual Inside Mechanical Seals with Silicon Carbide Face

Isolated in the oil chamber where a clean, non-corrosive and abrasion-free lubricating environment is maintained. Compared with the water-cooled outside mechanical seal, it reduces the risk of failure caused by dry-heating and adhering matter. The silicon carbide provides 5 times higher corrosion, wear and heat resistance than the tungsten carbide.

4 Oil Lifter

Provides lubrication and cooling of the seal faces down to 1/3 of normal oil level, thus maintaining a stable shaft sealing effect and prolonging seal life longer. The Oil Lifter is Tsurumi original design.

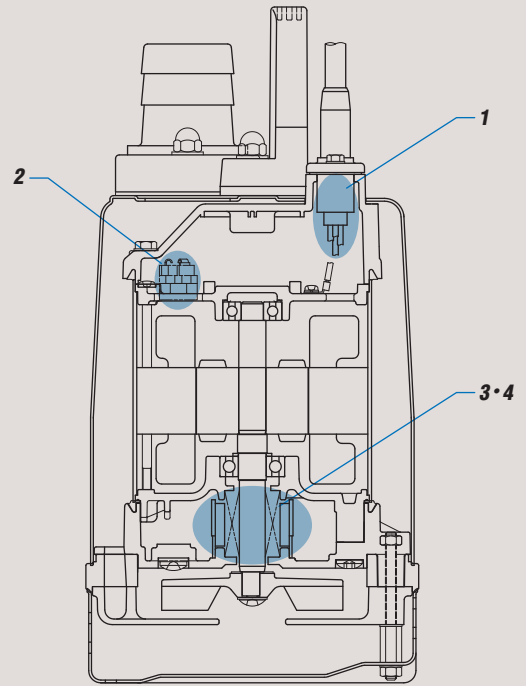

Performance Curves

Standard and Automatic models have the identical performance.

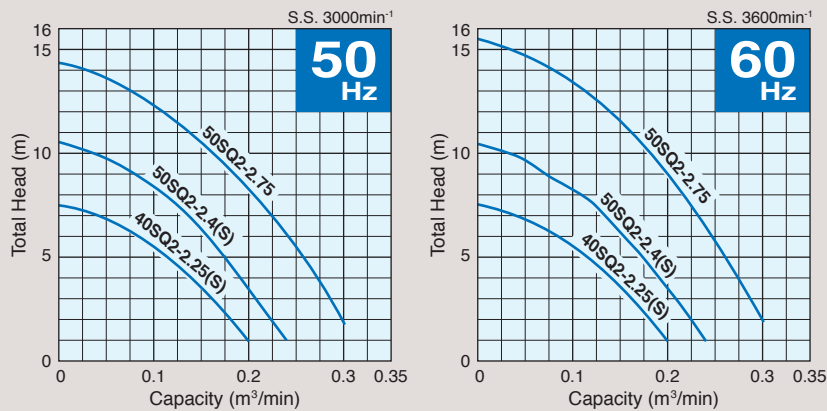

Dimensions

Unit: mm C.W.L.: Continuous Running Water Level

Standard Model

Automatic Model

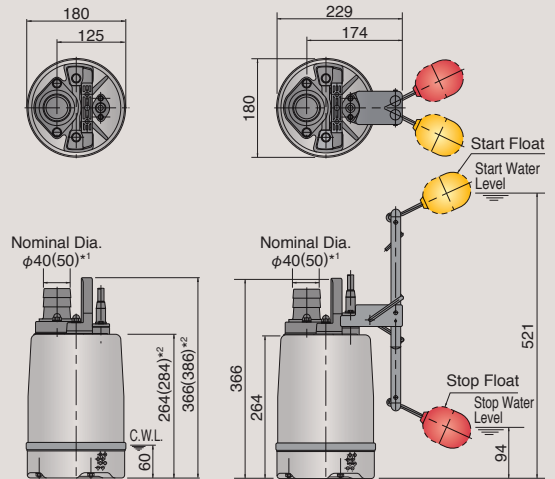

*1 The figure in parentheses is for 0.4 and 0.75kW models.
*2 The figure in parentheses is for 0.75kW model.

Model Selection

Discharge Bore mm	Model		Motor Output kW	Phase	Starting Method	Solids Passage mm	Dry Weight kg		Cable Length m
	Standard	Automatic					Standard	Automatic	
40	40SQ2-2.25S	40SQA2-2.25S	0.25	Single	Capacitor Run	6	10.5	11	5
40	40SQ2-2.25	—	0.25	Three	D.O.L.	6	10.5	—	5
50	50SQ2-2.4S	50SQA2-2.4S	0.4	Single	Capacitor Run	6	10.5	11	5
50	50SQ2-2.4	—	0.4	Three	D.O.L.	6	10.5	—	5
50	50SQ2-2.75	—	0.75	Three	D.O.L.	6	12	—	5

• Weights excluding cable

Product images and specifications may differ from actual products due to improvements. The OO series and model OO are indicated with our series/model codes in this catalog.

TSURUMI
MANUFACTURING CO., LTD.

www.tsurumi-global.com



Your Dealer