



**B - SERIES
SEWAGE & WASTEWATER PUMPS**

SPECIFICATIONS

■ FEATURES

1. Semi-open, Single vane, impellers with field adjustable /replaceable shear plate and, Enclosed Multi-vane, impellers, with field adjustable / replaceable wear plate provides for high wear resistance and enhanced solids handling capability.
2. Highly efficient, continuous duty air filled, copper wound motor with class E, B, F insulation minimizes the cost of operation.
3. Built in thermal protection prevents motor failure due to overloading, accidental run-dry and single phasing in three phase units.
4. Double inside mechanical seals with silicon carbide faces, running in an oil filled chamber, equipped with an oil lifter,, and further protected by an exclusionary oil Seal(s), provides for the most -

- durable seal design available.

5. Double shielded, permanently lubricated, high temperature C3 ball bearings rated for a B-10 life of 60,000 hours provide for extended operational life.

■ APPLICATIONS

1. Commercial, Industrial sewage, wastewater, or effluent transfer.
2. Decorative fountains and aquiculture .
3. Raw water supply from rivers or lakes.

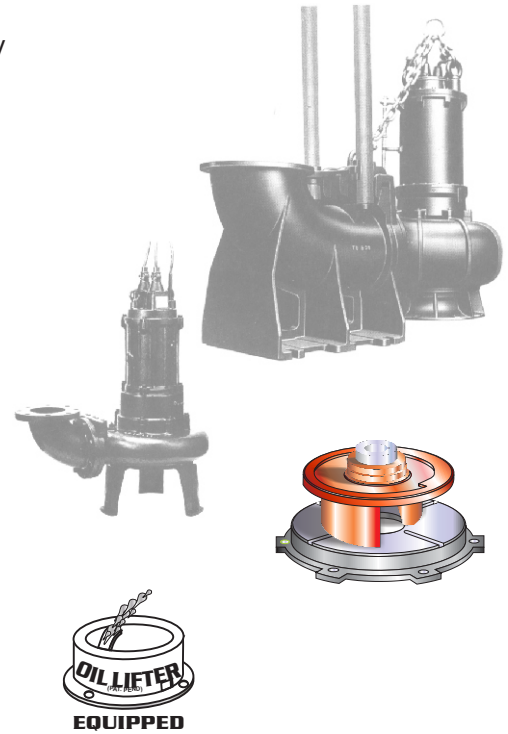

■ SPECIFICATIONS

- Discharge Size
- Horsepower Range
- Performance Range, Capacity Head
- Maximum water temperature
- Materials of Construction
 - Casing
 - Impeller
 - Shaft
 - Motor Frame
 - Fasteners
- Mechanical Seal
 - Elastomers
- Impeller Type
- Solids Handling Capability
- Bearings
- Motor Nomenclature
 - Type, Speed, Hz.
- Voltage, Phase
- Insulation
- Accessories
- Operational Mode

■ STANDARD

- 2" ~ 8" (50 ~ 200 mm)
- 1 Hp. ~ 20 Hp. (.75 kW ~ 20 kW)
- 20 ~ 1850 G.P.M. (.08 ~ 7.00 m³/min)
- 8.2 Ft.~105.0 Ft. (2.5 ~ 32.0m)
- 104° F. (40° C.)
- Cast Iron, ASTM 48 Class 35
- Cast Iron, ASTM 48 Class 35
- 403,420 Stainless Steel
- Cast Iron, ASTM 48 Class 30
- 304 Stainless Steel
- Silicon Carbide
- NBR (Nitril Buna Rubber)
- Semi-open, Enclosed, solids handling.
- .79" ~ 2.95" (20 ~ 75 mm)
- Pre-lubricated, Double Shielded
- Air Filled,
- 3600, 1800 & 1200 Rpm, 60 Hz.
- 115 or 230 (1Phase)
- 208-230, 460 or 575 V., (3 Phase)
- Class E, B, F
- Submersible Power Cable 32' (10 m)
- Manual

■ OPTIONS

- Dry-Pit
- Nema 3R inverter available for 230 V., 1 Ph. operation from 2~5 Hp.
- Length as required.
- TO/TOS Slide Rail System