

SFQ • SQ | Corrosion resistant stainless steel pumps



80SFQ211



50SQ2-2.4S

Material

Model	SFQ	SQ
Impeller:	316 Stainless Steel	Resin
Casing:	316 Stainless Steel	304 SS & Rubber
Mechanical Seal:	Silicon Carbide	Silicon Carbide
Motor Frame:	316 Stainless Steel	304 Stainless Steel
Shaft:	316 Stainless Steel	304 Stainless Steel
Fasteners:	316 Stainless Steel	304 Stainless Steel
Cable:	PVC Sheath Chloroprene Sheath	PVC Sheath



Group Performance: SFQ

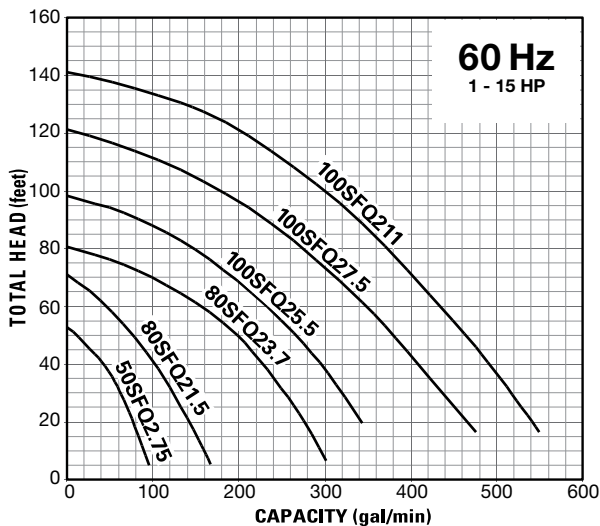

Group Performance: SQ

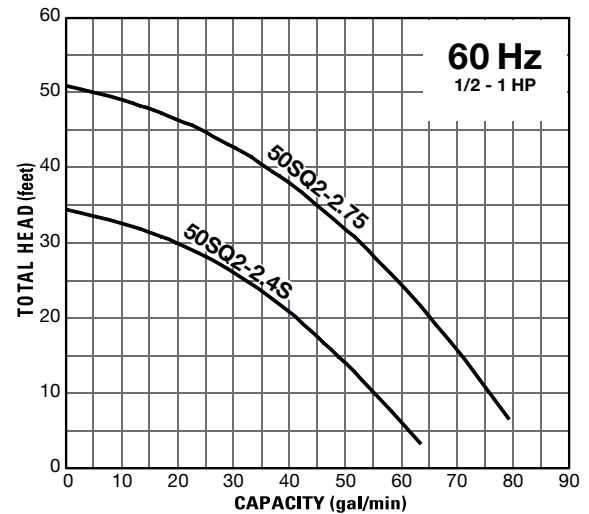

Features

SFQ Series

- All wetted components are 316 Stainless Steel
- Viton elastomers
- Dual inside mechanical seals with Silicon Carbide faces, operate in an oil filled chamber
- Built in motor protector
- Semi-open, SCS14 stainless steel impeller
- Seal pressure relief system features (7.5 - 15HP)
- Optional 316 SS Guide rail system is available for models from 7.5 - 15hp.

SQ Series

- It is made of 304/316 stainless steel, Nitrile Butadiene Rubber and special resin to stand up to rust and corrosion, and sport a new structural design that makes them even lighter and easier to carry
- Non-toxic white mineral oil used to lubricate mechanical seals allows for use in food / agriculture industries
- Motor protector protects against overheating and run-dry
- Designed to fit into an 8-inch pipe

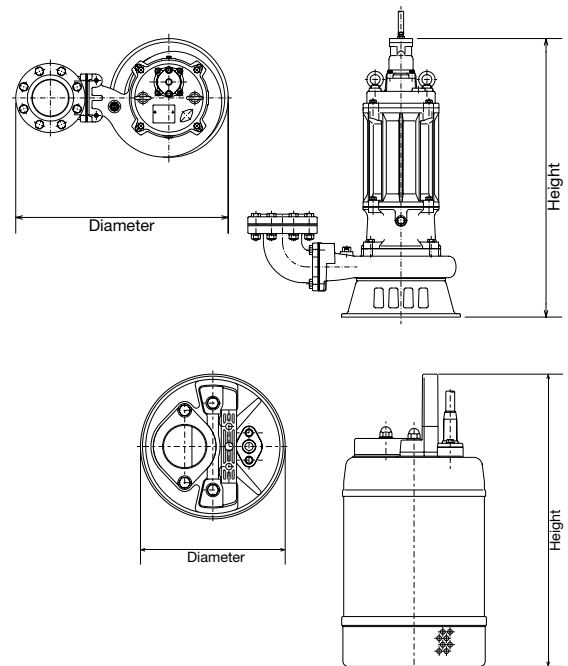
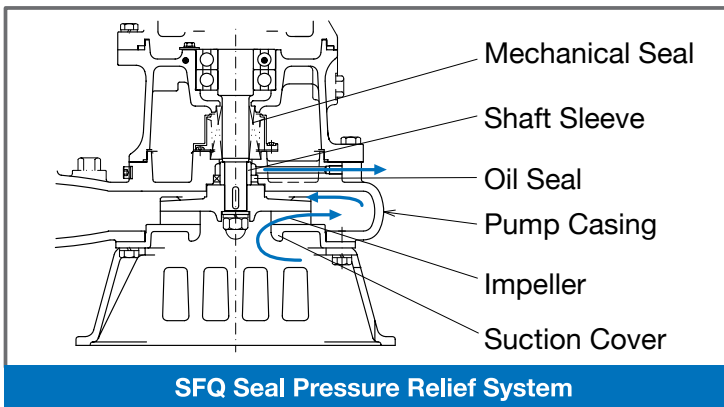

MODEL	MOTOR SPECIFICATIONS								RPM	Discharge Size (inch)	DIMENSION		Max. Solids Dia. (inch)	Continuous Running Water Level (in.)	Pump Weight (lbs.)
	Motor Output (HP)	Phase	Rated Current (A)												
			Single phase		Three phase										
115V	230V	208V	230V	460V	575V	Diameter (in.)	Height (in.)								
50SFQ2.75	1	Three	—	—	3.5	3.1	1.6	1.4	3430	2	9 15/16	15 11/16	0.236	14 1/8	49
80SFQ21.5	2	Three	—	—	6.9	6.7	3.4	2.7	3450	3	12 15/16	19 1/16	0.236	16 3/8	79
80SFQ23.7	5	Three	—	—	13.8	12.8	6.4	5	3410	3	14 1/8	21 5/16	0.591	19 1/2	115
100SFQ25.5	7.5	Three	—	—	19.3	18.2	9.4	7.5	3545	4	25 3/8	33 1/4	0.787	27 1/8	278
100SFQ27.5	10	Three	—	—	26.0	24.4	12.2	9.5	3545	4	25 3/8	33 1/4	0.787	27 1/8	276
100SFQ211	15	Three	—	—	37.0	35.2	17.6	13.9	3525	4	25 3/8	35 1/8	0.906	28	320

MODEL	MOTOR SPECIFICATIONS								RPM	Discharge Size (inch)	DIMENSION		Max. Solids Dia. (inch)	Continuous Running Water Level (in.)	Pump Weight (lbs.)
	Motor Output (HP)	Phase	Rated Current (A)												
			Single phase		Three phase										
115V	230V	208V	230V	460V	575V	Diameter (in.)	Height (in.)								
50SQ2-2.4S	1/2	Single	6.5	3.4	—	—	—	—	3376	2	7 1/16	14 7/16	0.236	2 3/8	23
50SQ2-2.75	1	Three	—	—	3.5	3.4	1.6	1.3	3349	2	7 1/16	15 3/16	0.236	2 3/8	26