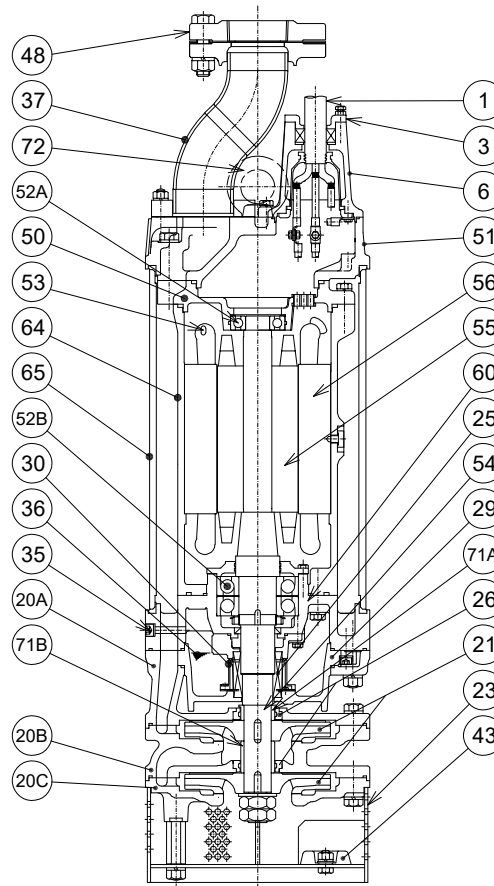

LH322W-14-61

ITEM#	DESCRIPTION	MAIN MATERIAL / NOTE	ASTM, AISI CODE	RELATED EN CODE	Q'TY
1	Power Cable	Chloroprene Sheath AWG 4/3, 6/1, 14/2 -65ft			1
3	Gland	Stainless Steel Casting	A743 CF-8M	GX5CrNiMo19-11-2	1
6	Stuffing Box	Stainless Steel Casting	A743 CF-8M	GX5CrNiMo19-11-2	1
20A	Upper Pump Casing	Stainless Steel Casting	A743 CF-8M	GX5CrNiMo19-11-2	1
20B	Middle Pump Casing	Stainless Steel Casting	A743 CF-8M	GX5CrNiMo19-11-2	1
20C	Lower Pump Casing	Stainless Steel Casting	A743 CF-8M	GX5CrNiMo19-11-2	1
21	Impeller	Stainless Steel Casting	A743 CF-8M	GX5CrNiMo19-11-2	2
23	Suction Strainer	Stainless Steel	S 31600	1.4401	1
25	Mechanical Seal	Silicon Carbide / HT-4550N			1
26	Labyrinth Ring	Stainless Steel	S 31600	1.4401	2
29	Oil Casing	Stainless Steel Casting	A743 CF-8M	GX5CrNiMo19-11-2	1
30	Oil Lifter	PBT Resin W/GF40			1
35	Oil Plug	Stainless Steel	S 31600	1.4401	3
36	Lubricant	Turbine Oil ISO VG32 or SAE 10W-20			
37	Discharge Pipe	Stainless Steel / 3" JIS10K	S 31600	1.4401	1
43	Cathodic Protection Plate	Aluminium Alloy			2
48	Companion Flange	Stainless Steel Casting / NPT 3" JIS10K	A743 CF-8M	GX5CrNiMo19-11-2	1
50	Motor Bracket	Stainless Steel Casting	A743 CF-8M	GX5CrNiMo19-11-2	1
51	Head Cover	Stainless Steel Casting	A743 CF-8M	GX5CrNiMo19-11-2	1
52A	Upper Bearing	#6307ZC3			1
52B	Lower Bearing	#7311DBC3			1
53	Motor Protector				3
54	Shaft	Stainless Steel (Wet end)	S 31600	1.4401	1
55	Rotor				1
56	Stator				1
60	Bearing Housing	Stainless Steel Casting	A743 CF-8M	GX5CrNiMo19-11-2	1
64	Motor Housing	Stainless Steel Casting	A743 CF-8M	GX5CrNiMo19-11-2	1
65	Outer Cover	Stainless Steel	S 31600	1.4401	1
71A	Shaft Sleeve (Upper)	Stainless Steel	S 31600	1.4401	1
71B	Shaft Sleeve (Lower)	Stainless Steel	S 31600	1.4401	1
72	Lifting Lug Bolt	Stainless Steel	S 31600	1.4401	2