

100AB2.75-61

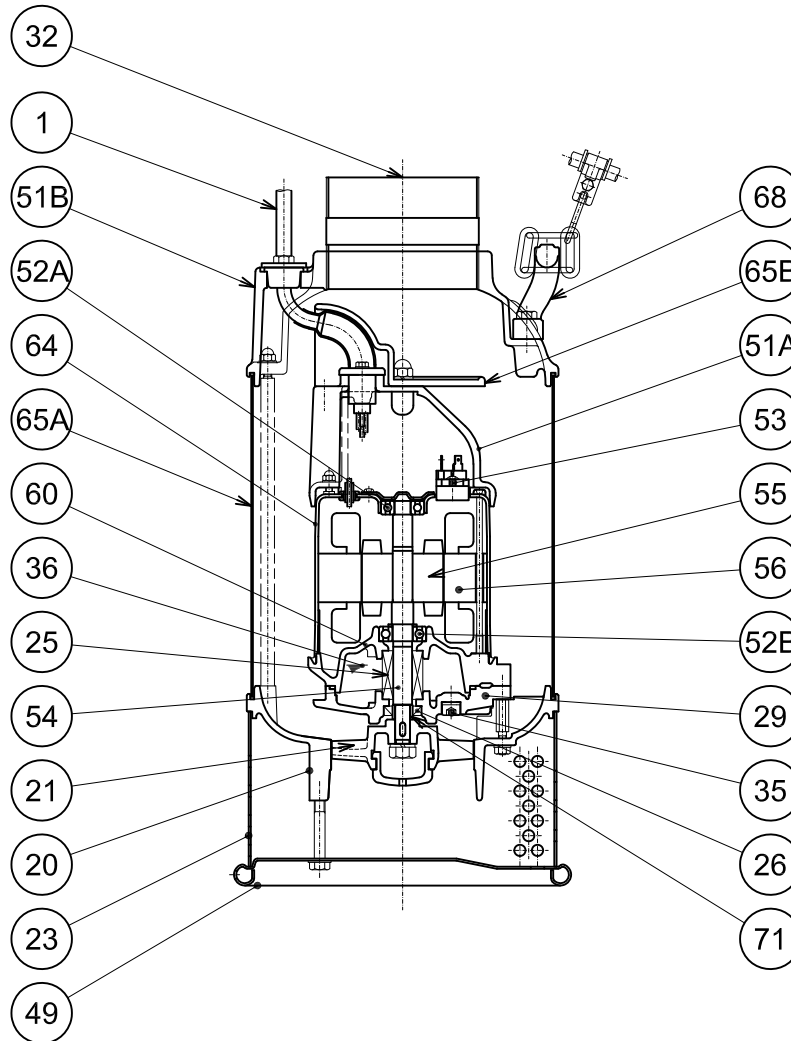

PART#	DESCRIPTION	MAIN MATERIAL / NOTE	ASTM, AISI CODE	RELATED DIN CODE	QTY
1	Power Cable	PVC Sheath AWG16/4-32ft			1
20	Pump Casing	Cast Iron	A48MClass30B	EN 1561 GJL-200	1
21	Impeller	Cast Iron	A48MClass30B	EN 1561 GJL-200	1
23	Suction Strainer	Steel (Cold Rolled)	A109/A1008	EN 10130	1
25	Mechanical Seal	Silicon Carbide / W-14HC			1
26	Oil Seal	Nitrile Butadiene Rubber / SC-15287			1
29	Oil Casing	Cast Iron	A48MClass30B	EN 1561 GJL-200	1
32	Discharge Connection	Cast Iron / NPT 4"	A48MClass30B	EN 1561 GJL-200	1
35	Oil Plug	Stainless Steel	S 30400	1.4301	1
36	Lubricant	White Mineral Oil ISO VG32			
49	Bottom Plate	Steel (Cold Rolled)	A109/A1008	EN 10130	1
51A	Motor Head Cover	Aluminium Alloy Die Casting	B85 383.0	EN 1706 AC-46100	1
51B	Pump Head Cover	Cast Iron	A48MClass30B	EN 1561 GJL-200	1
52A	Upper Bearing	#6201ZZC3			1
52B	Lower Bearing	#6202ZZC3			1
53	Motor Protector				1
54	Shaft	Stainless Steel	S 40300	1.4000	1
55	Rotor				1
56	Stator				1
60	Bearing Housing	Cast Iron	A48MClass25B	EN 1561 GJL-150	1
64	Motor Housing	Steel (Cold Rolled)	A109/A1008	EN 10130	1
65	Outer Cover	Stainless Steel	S 30400	1.4301	1
68	Handle	Cast Iron	A48MClass30B	EN 1561 GJL-200	2
71	Shaft Sleeve	Stainless Steel	S 40300	1.4000	1