

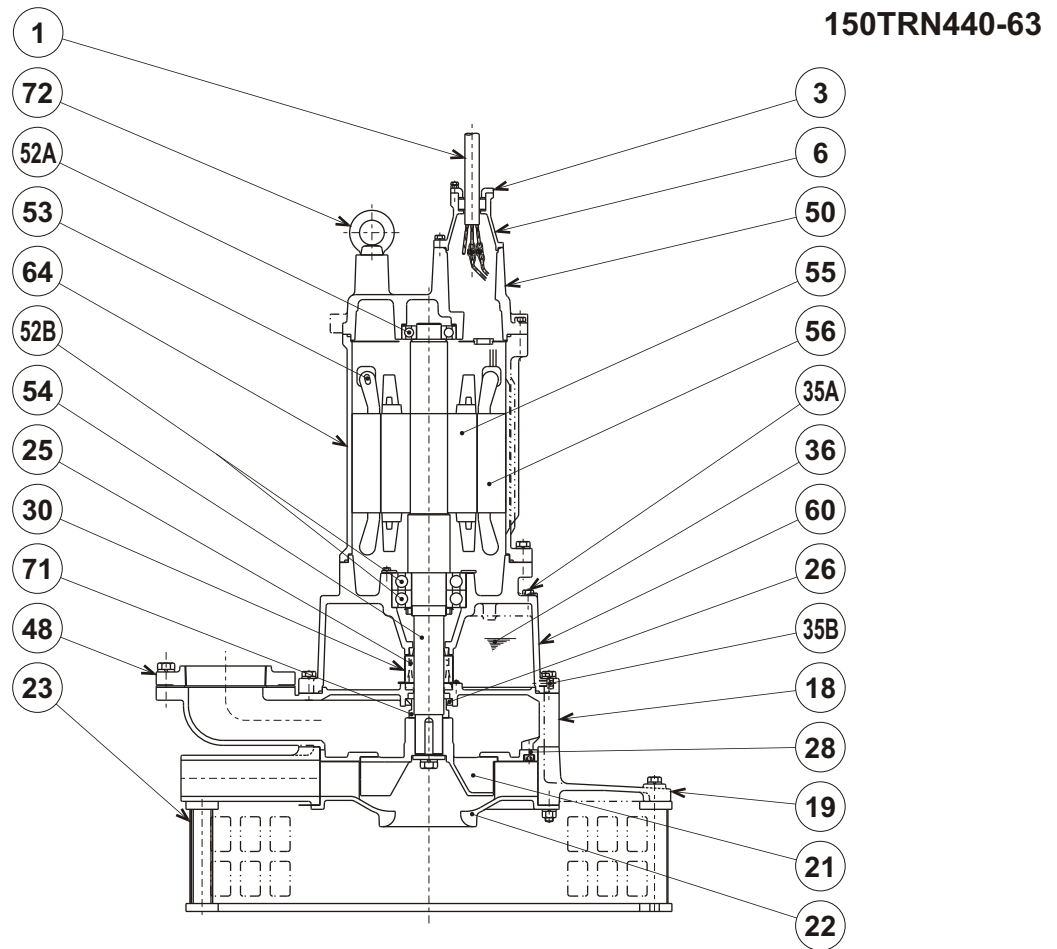

TSURUMI PUMP

**TRN - SERIES
SUBMERSIBLE - AERATOR**

SECTIONAL VIEW



PART#	DESCRIPTION	MAIN MATERIAL / NOTE	ASTM, AISI CODE	RELATED DIN CODE	QTY
1	Power Cable	Chloroprene Sheath AWG4/4, 4/3, 16/2- 32ft			3
3	Gland	Cast Iron	A48M Class30B	EN 1561 GJL-200	2
6	Stuffing Box	Cast Iron	A48M Class25B	EN 1561 GJL-150	2
18	Air Passage	Cast Iron	A48M Class30B	EN 1561 GJL-200	1
19	Guide Vane	Cast Iron	A48M Class30B	EN 1561 GJL-200	1
21	Impeller	Stainless Steel Casting	A743 CA-15	X15Cr13	1
22	Suction Cover	Stainless Steel Casting	A743 CA-15	X15Cr13	1
23	Suction Strainer	Steel + Stainless Steel	A283 Grade D + S 30400	EN 10025 S275 + 1.4301	1
25	Mechanical Seal	Silicon Carbide / H-60			1
26	Oil Seal	NBR / VC-709513			1
28	Middle Plate	Stainless Steel Casting	A743 CA-15	X15Cr13	1
30	Oil Lifter	PBT Plastic w/(GF+MD)40			1
35A	Oil Plug	Stainless Steel	S 30400	1.4301	2
35B	Oil Plug	Stainless Steel	S 30400	1.4301	2
36	Lubricant	Turbine Oil ISO VG32 or SAE 10W-20			
48	Companion Flange	Cast Iron / NPT 6"	A48M Class30B	EN 1561 GJL-200	1
50	Motor Bracket	Cast Iron	A48M Class30B	EN 1561 GJL-200	1
52A	Upper Bearing	6310ZZC3			1
52B	Lower Bearing	6314ZZD2C3			1
53	Motor Protector				3
54	Shaft	Stainless Steel	S 42000	1.4028	1
55	Rotor				1
56	Stator				1
60	Bearing Housing	Cast Iron	A48M Class30B	EN 1561 GJL-200	1
64	Motor Housing	Cast Iron	A48M Class30B	EN 1561 GJL-200	1
71	Shaft Sleeve	Stainless Steel	S 30400	1.4301	1
72	Lifting Lug Bolt	Stainless Steel	S 30400	1.4301	2