

PARTS LIST		SUBMERSIBLE AERATOR			8/20/2012	
ITEM	PART No.	DESCRIPTION	QTY	SIZE	MATERIAL	NOTES
1	140-052-17	Hex.Bolt	2	M8x16	SUS304	
2	127-000-16	Protector Fixing Plate	1		SUS304	
3	121-000-23	Packing	1		NBR	
4	053-000-33	Motor Protector 230V-60Hz(USA)		KA313-GGVL110	(T.C)	
	053-420-17	Motor Protector 460V-60Hz(USA)		KA313-GCXL103	(T.C)	
5	143-126-12	Pan Screw (w/Spring Washer/Plain Washer)	2	M4x12	SWRM	
6	001-001-88	Cabtyre Cable Set(10m)230V-60Hz(USA)	1	VCT4Cx3.5mm2	BE(40)	
	001-001-88	Cabtyre Cable Set(10m)460V-60Hz(USA)	1	VCT4Cx3.5mm2	BE(40)	
7	140-021-17	Hex.Bolt	3	M5x20	SUS304	
9	009-275-18	Compression type Terminal	4	TGNB-5.5(Insulated)	CU	
10	072-102-22	Eye Bolt	2	M12	SUS304	
11	140-057-12	Hex.Bolt	3	M8x35	SUS304	
12	142-163-18	Spring Washer	3	M8	SUS304	
13	064-000-46	Motor Frame	1		FC	
14	009-293-12	Earth Terminal	1Set	2mm2x180L		interchangable with OLD part# 009-212-17 (L=130)
15	143-085-21	Pan Screw (w/Spring Washer)	1	M4x6	SWRM	
16	122-333-19	O-Ring	1	170xd3.1	NBR	
17	058-000-04	Lead Wire Protection Plate	1	d66xd150x1.5t	Bakelite	
18	142-196-10	Wave Washer	1	6205/6304	SK5	
19	052-188-17	Bearing (w/O-ring)	1	AC-6304ZZC3		
20	056-001-35	Stator 230V-60Hz(USA)	1Set			
	056-001-45	Stator 460V-60Hz(USA)	1Set			
21	055-000-77	Rotor	1Set			
22	147-081-16	Impeller Key	1	7x7x22l	SUS420	
23	140-000-06	Hex.Bolt (w/Spring Washer/Plain Washer)	3	M6x12	SWCH	
24	052-112-10	Bearing	1	6309ZZC3		
25	140-112-16	Hex.Bolt	4	M12x110	SUS304	
26	142-165-10	Spring Washer	4	M12	SUS304	
27	035-113-18	Oil Plug	2	M12x14	SUS304	
28	121-247-12	Packing	2	d12.3xd18x2t	PE	
29	140-099-16	Hex.Bolt	4	M12x40	SUS304	
30	142-165-10	Spring Washer	4	M12	SUS304	
31	060-000-45	Bearing Housing	1		FC	
32	025-194-12	Mechanical Seal	1	H-30	SIC	
33	143-070-23	Pan Screw	2	M5x6	SWRM	
34	030-142-11	Oil Lifter	1	H-30(A)(T)	Resin	
35	143-070-10	Pan Screw	3	M5x6	SWRM	
36	030-151-13	Seal Stopper	1	H-30(A)(T)	SPCC	
37	122-265-19	O-Ring	1	335xd5.7	NBR	
38	018-103-12	Air Passage	1	22-TR	FC	
39	026-199-23	Distance Piece	1	22-TR	SGP	
40	026-000-09	Oil Seal	1	VC-30486	NBR	
41	028-000-28	Middle Plate(60Hz)	1	50TRN42.2	SUS410	
42	140-096-13	Hex.Bolt	3	M12x25	SUS304	

PARTS LIST		SUBMERSIBLE AERATOR			8/20/2012	
ITEM	PART No.	DESCRIPTION	QTY	SIZE	MATERIAL	NOTES

EXPLODED VIEW

50TRN43.7-62

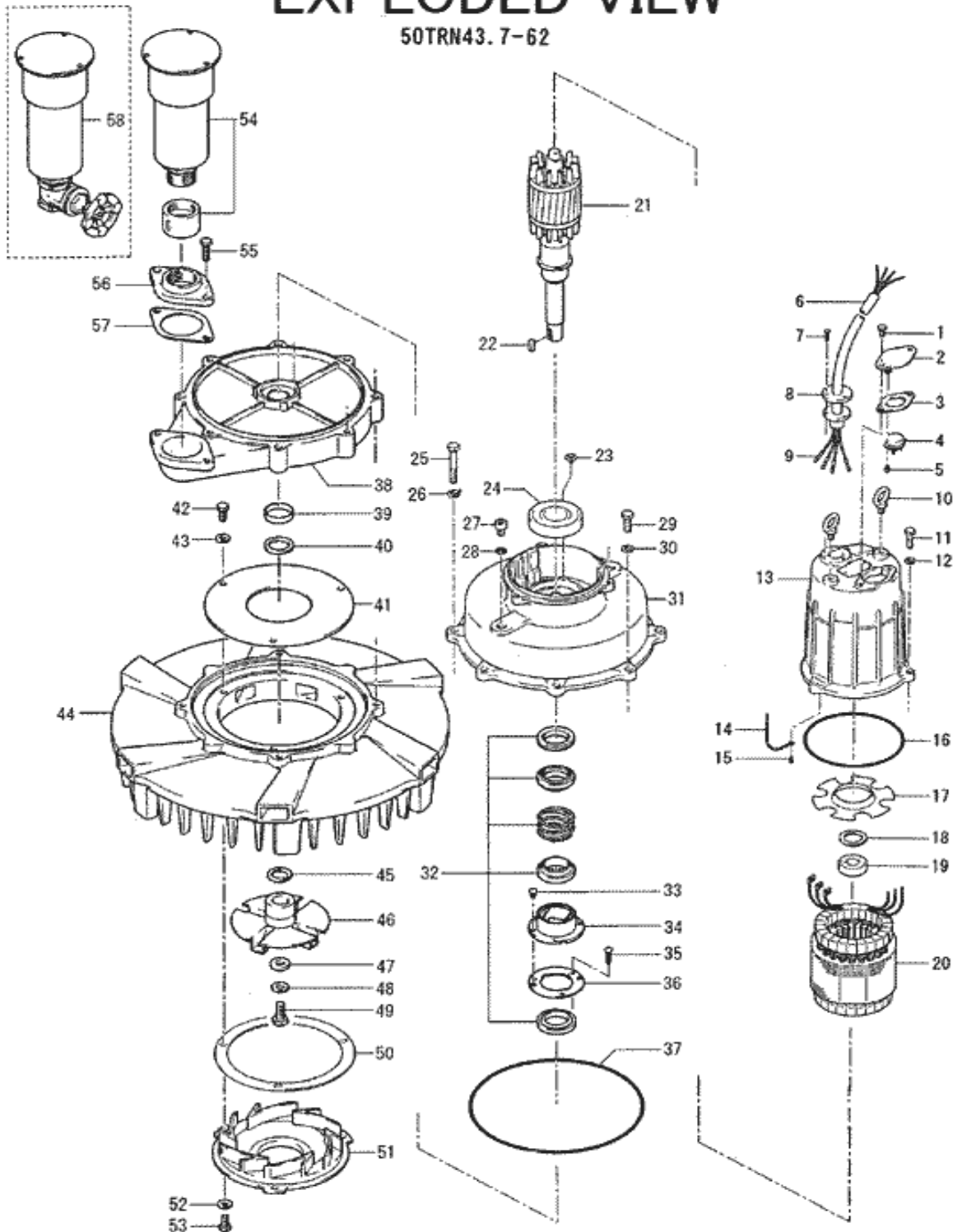

C-00947-1