

PARTS LIST		SUBMERSIBLE AERATOR			11/15/2013	
ITEM	PART No.	DESCRIPTION	QTY	SIZE	MATERIAL	NOTES
1	009-116-10	Terminal	2	R-2-4	CU	
2	140-018-11	Hex.Bolt	3	M5x15	SUS304	
3	142-422-18	Seal Washer	3	PM-5	SUS+NBR	
4	003-111-20	Gland	1		SUS304	
5	001-005-66	Cabtyre Cable Set (32') 60Hz (USA)	1	2PNCT2Cx1.25mm2	BE/CE	
6	009-274-17	Compression type Terminal	2	TMNB-2(Insulated)		
7	009-107-18	Terminal	7	R-14-6	CU	** included in ITEM 12 cable assembly ***included in ITEM 14 cable assembly
8	140-035-14	Hex.Bolt	4	M6x20	SUS304	** included in ITEM 12 cable assembly ***included in ITEM 14 cable assembly
9	070-107-18	Cable Clamp	2		FC	** included in ITEM 12 cable assembly ***included in ITEM 14 cable assembly
10	140-488-16	Hex.Bolt (w/Spring Washer)	8	M8x30	SUS304	
11	006-127-15	Stuffing Box	2	No.3	FC	** included in ITEM 12 cable assembly ***included in ITEM 14 cable assembly
12	001-007-76	Cabtyre Cable Set (32') 60Hz (USA)	1	2PNCT4Cx14mm2	No.3	
13	008-147-17	Mould Cover	1	KR3-9	CR	**included in ITEM 12 cable assembly
14	001-007-77	Cabtyre Cable Set (32') 60Hz (USA)	1	2PNCT3Cx14mm2	No.3	
15	008-150-13	Mould Cover	1	KR3-12	CR	**included in ITEM 14 cable assembly
16	140-029-31	Hex.Bolt	7	M6x10	C3604	
17	009-107-18	Terminal	7	R-14-6	CU	** included in ITEM 12 cable assembly ***included in ITEM 14 cable assembly
18	009-107-18	Terminal	6	R-14-6	CU	
19	141-004-46	Hex.Nut	7	M6	C3604	
20	002-115-18	Heat Shrink Tube (Sold per meter)	m	EVA(d16.5x1t)	(Vm)	
21	002-116-19	Heat Shrink Tube (Sold per meter)	m	A4(d20x0.35t)	(Vm)	
22	143-041-12	Pan Screw	1	M6x8	SWRM	
23	142-162-33	Spring Washer	1	M6	SWRH	
24	009-106-17	Terminal	2	R-8-6	CU	
25	072-103-23	Eye Bolt	2	M24	SUS304	
26	142-000-01	Washer		d25xd44x0.1t	SUS304	
	142-000-02	Washer		d25xd44x0.3t	SUS304	
27	035-102-30	Air Tightness Test Plug	1	M12x16(B=21)	SUS304	
28	122-259-10	O-Ring	1	12xd3	NBR	*
29	140-099-16	Hex.Bolt	6	M12x40	SUS304	
30	142-165-10	Spring Washer	6	M12	SUS304	
31	050-491-10	Motor Bracket	1		FC	
32	122-159-19	O-Ring	1	G-280(279.3xd5.7)	NBR	*
33	142-201-19	Wave Washer	1	6309	SK5	
34	122-131-15	O-Ring	1	G-100(99.4xd3.1)	NBR	
35	052-112-10	Bearing	1	6309ZC3		
36	058-000-14	Lead Wire Protection Plate	1	d110xd289x1.5t	SPHC	
37	055-878-10	Rotor	1Set			
38	147-005-16	Impeller Key	1	12x8x40	SUS304	
39	053-001-56	Motor Protector	3	F-11	(H)	
40	056C4919	Stator 230V-60Hz(USA)	1Set			
	056C5912	Stator 460V-60Hz(USA)	1Set			
41	064-565-19	Motor Frame	1		FC	
42	142-297-12	Seal Washer	2	SM-10	SUS+NBR	

* Indicates items included in set

PARTS LIST		SUBMERSIBLE AERATOR			11/15/2013	
ITEM	PART No.	DESCRIPTION	QTY	SIZE	MATERIAL	NOTES
43	140-000-08	Hex.Bolt	2	M10x18	SUS304	
44	140-101-12	Hex.Bolt	6	M12x50	SUS304	
45	142-165-10	Spring Washer	6	M12	SUS304	
46	122-159-19	O-Ring	1	G-280(279.3xd5.7)	NBR	*
47	140-054-48	Hex.Bolt	4	M8x20	SWRM	
48	142-163-34	Spring Washer	4	M8	SWRH	
49	062-228-11	Bearing Fixing Plate	1		SS	
50	052-143-10	Bearing	1Set	6312ZZD2C3		
51	142-245-15	Bearing Washer	1	AW12	SPCC	
52	141-077-11	Bearing Nut	1	AN12	SS	
53	140-138-18	Hex.Bolt	4	M16x130	SUS304	
54	142-166-11	Spring Washer	4	M16	SUS304	
55	140-127-14	Hex.Bolt	3	M16x55	SUS304	
56	142-166-11	Spring Washer	3	M16	SUS304	
57	035-113-18	Oil Plug	2	M12x14	SUS304	
58	121-247-12	Packing	2	d12.3xd18x2t	PE	*
59	140-124-11	Hex.Bolt	1	M16x40	SUS304	
60	142-166-11	Spring Washer	1	M16	SUS304	
61	060-000-47	Bearing Housing	1		FC	
62	025-000-62	Mechanical Seal	1	H-45X(E)	SIC	changed from 025-197-15 by TB M63-003
63	143-070-23	Pan Screw	2	M5x6	SWRM	
64	030-140-19	Oil Lifter	1	H-45	Resin	
65	143-070-10	Pan Screw	3	M5x6	SWRM	
66	030-149-18	Seal Stopper	1	H-40/45	SPCC	
67	122-256-17	O-Ring	1	390xd5.7	NBR	*
68	018-000-02	Air Passage	1	100TR419/22-51/61	FC	
69	026-000-07	Distance Piece	1	80TR415-51/61	SS	
70	026-197-18	Oil Seal	1	VC-45686	NBR	
71	140-128-15	Hex.Bolt	4	M16x60	SUS304	
72	142-166-11	Spring Washer	4	M16	SUS304	
73	019-000-20	Guide Vane	1	100TRN422	FC	
74	028-000-34	Middle Plate	1	100TRN422-52/62	SCS1	
75	140-000-55	Hex.Socket Cap Bolt	4	M10x20	SUS304	
76	040-000-12	Impeller Washer		d40.5xd59	SUS304	
77	021-007-39	Impeller (60Hz)	1	100TRN422-62	SCS1	
78	142-101-18	Impeller Fixing Washer	1	d17xd50x6t	SUS304	
79	142-166-11	Spring Washer	1	M16	SUS304	
80	140-125-12	Hex.Bolt	1	M16x45	SUS304	
81	120-149-10	Packing		d411xd470x0.5t	PE	*
82	022-001-62	Suction Cover (60Hz)	1	100TRN424-62	SCS1	
83	144-432-17	Stud Bolt	4	M16x32(28/20)(JIS)	SUS304	
84	142-166-11	Spring Washer	4	M16	SUS304	
85	141-008-11	Hex.Nut	4	M16	SUS304	
86	023-000-57	Strainer Stand	1	300/370-TR	SS	

PARTS LIST		SUBMERSIBLE AERATOR			11/15/2013	
ITEM	PART No.	DESCRIPTION	QTY	SIZE	MATERIAL	NOTES

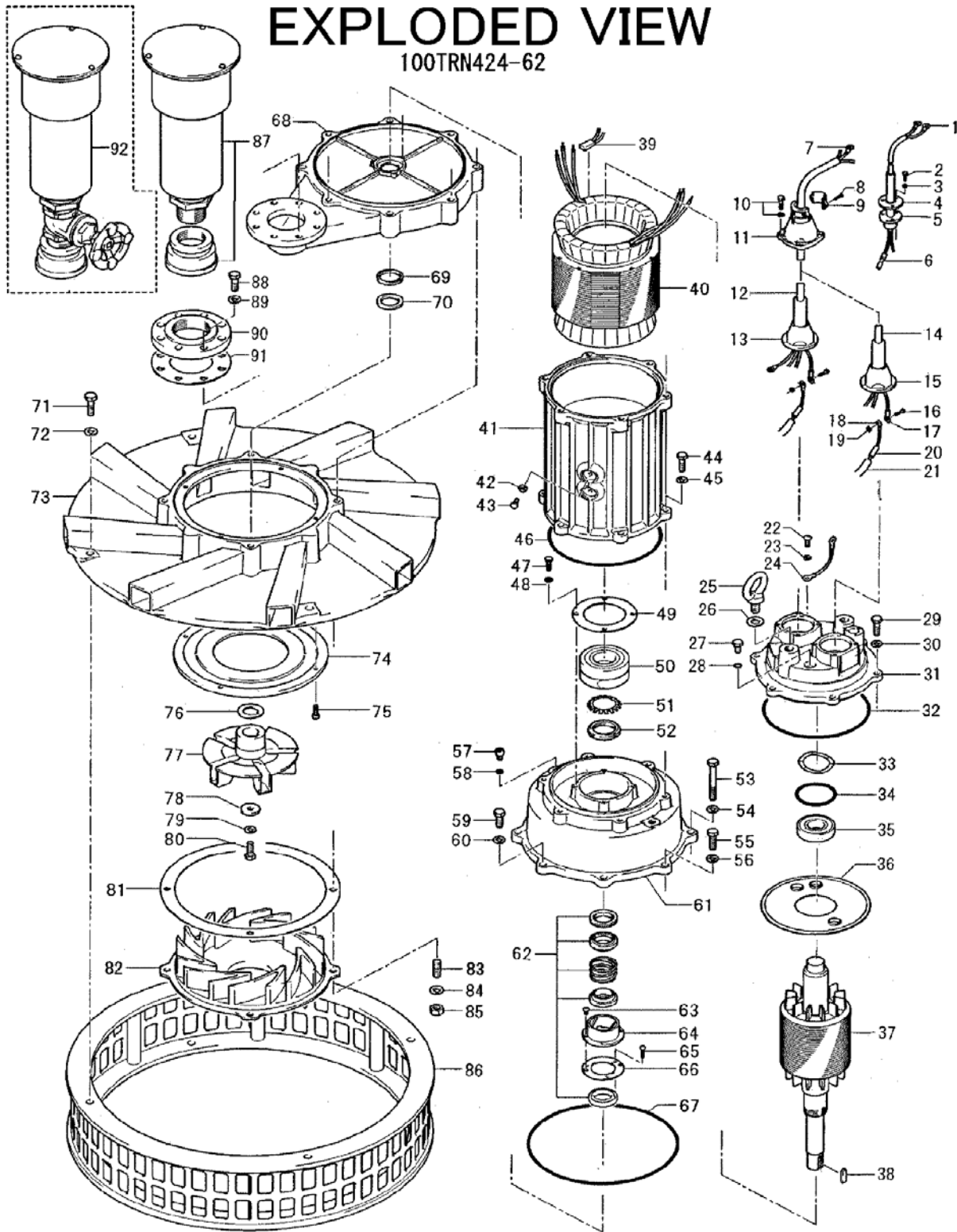

C-01055-1