

8-BER4

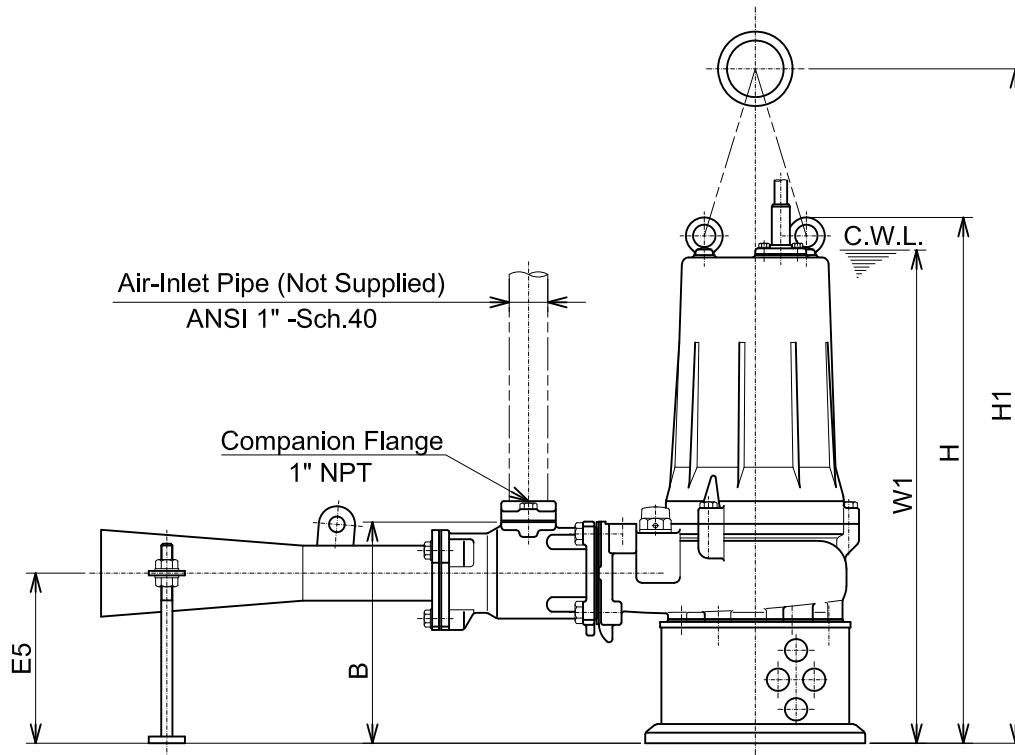
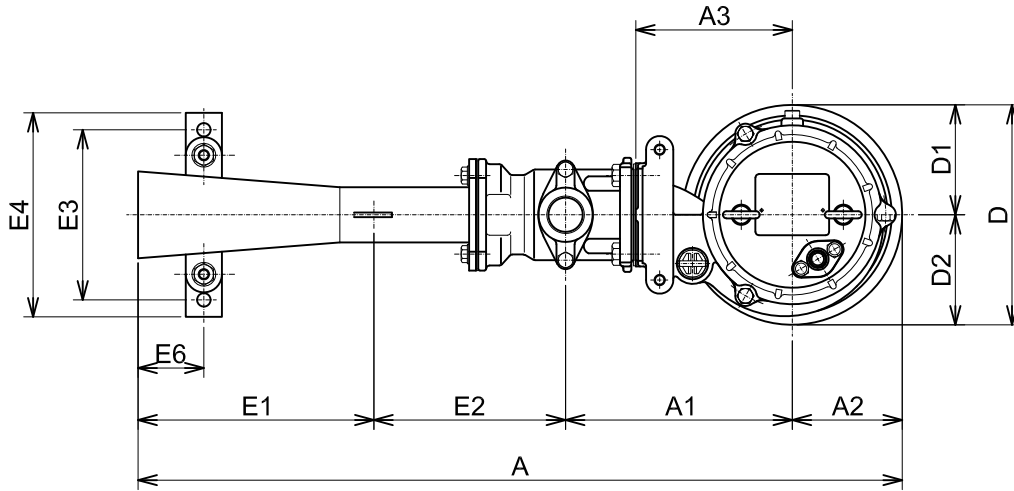

C.W.L. : Continuous running Water Level

DIMENSIONS:USCS (Inch)

Model	HP	Air-Inlet Dia.	Ejector Pump & Motor																	C.W.L. W1	*Wt. (lbs.)
			A	A1	A2	A3	B	D	D1	D2	H	H1	E1	E2	E3	E4	E5	E6			
8-BER4	1	1"	26 9/16	7 7/8	3 13/16	5 7/16	7 11/16	7 5/8	3 13/16	3 13/16	18 1/4	23 7/16	8 3/16	6 5/8	5 7/8	7 1/16	5 7/8	2 5/16	17 1/8	62	

*Excluding Cable

DIMENSIONS:METRIC (mm)

Model	kW	Air-Inlet Dia.	Ejector Pump & Motor																	C.W.L. W1	*Wt. (kg)
			A	A1	A2	A3	B	D	D1	D2	H	H1	E1	E2	E3	E4	E5	E6			
8-BER4	0.75	25	674	200	97	138	195	194	97	97	464	595	208	169	150	180	150	58	435	28	