

55-BER7

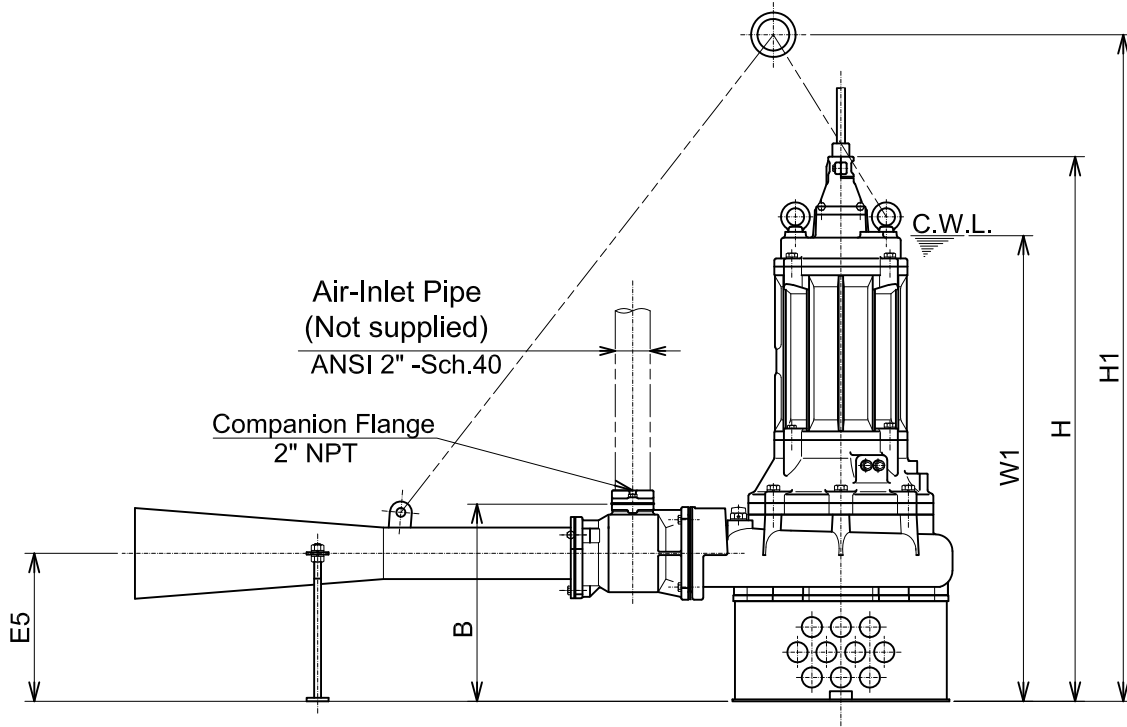
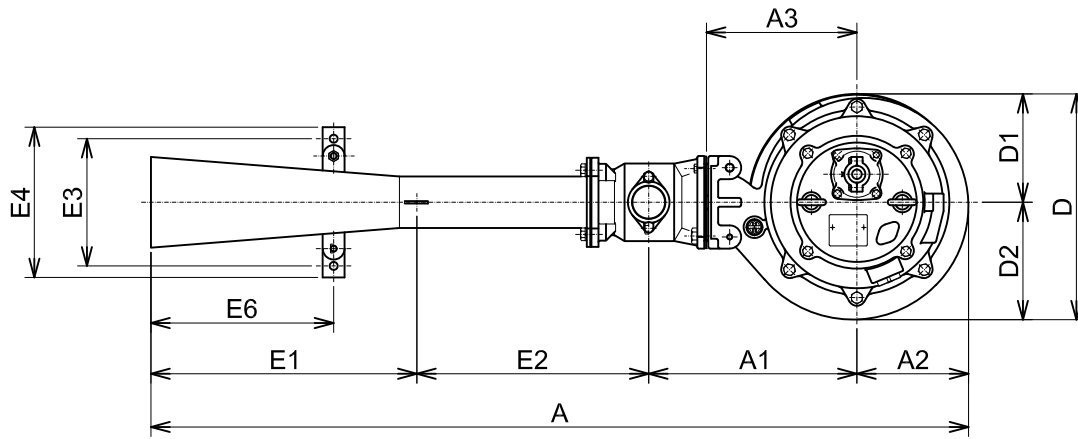

C.W.L. : Continuous running Water Level

DIMENSIONS:USCS (Inch)

Model	HP	Air-Inlet Dia.	Ejector Pump & Motor														C.W.L.	*Wt. (lbs.)		
			A	A1	A2	A3	B	D	D1	D2	H	H1	E1	E2	E3	E4			E5	E6
55-BER7	7.5	2"	55 11/16	14 3/16	7 5/8	10 1/4	13 7/16	15 3/8	7 3/8	8	37 1/16	45 3/8	18 1/8	15 13/16	8 11/16	10 1/4	10 1/16	12 7/16	31 3/4	328

DIMENSIONS:METRIC (mm)

Model	kW	Air-Inlet Dia.	Ejector Pump & Motor														C.W.L.	*Wt. (kg)		
			A	A1	A2	A3	B	D	D1	D2	H	H1	E1	E2	E3	E4			E5	E6
55-BER7	5.5	50	1415	360	194	260	341	391	188	203	942	1153	460	401	220	260	256	316	805	149

*Excluding Cable