

15-BER3

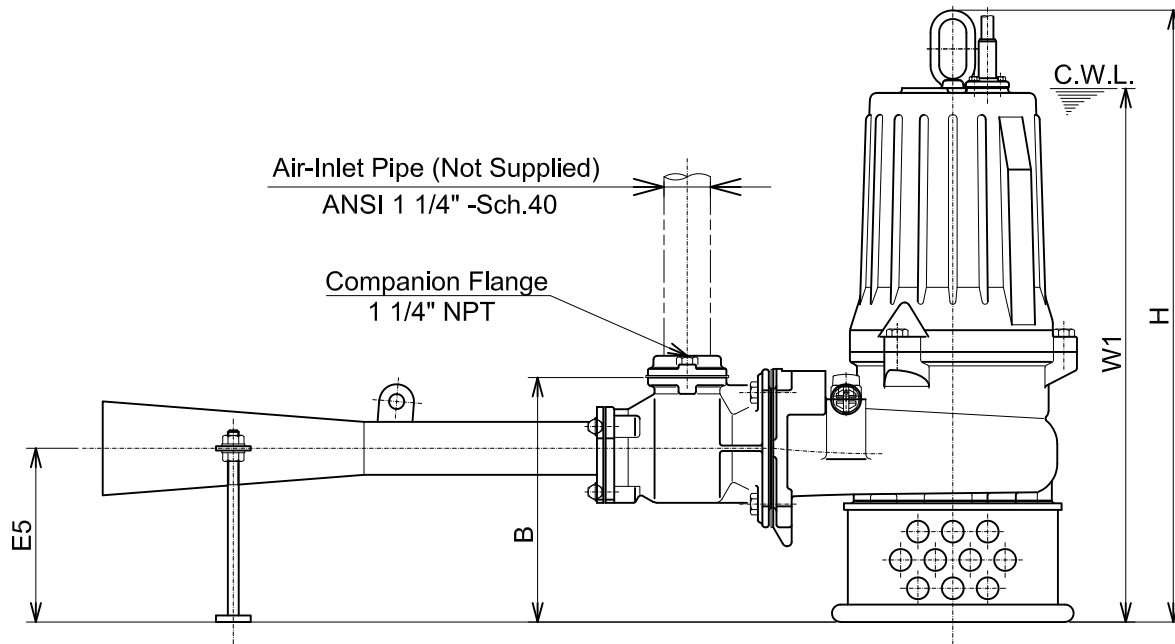
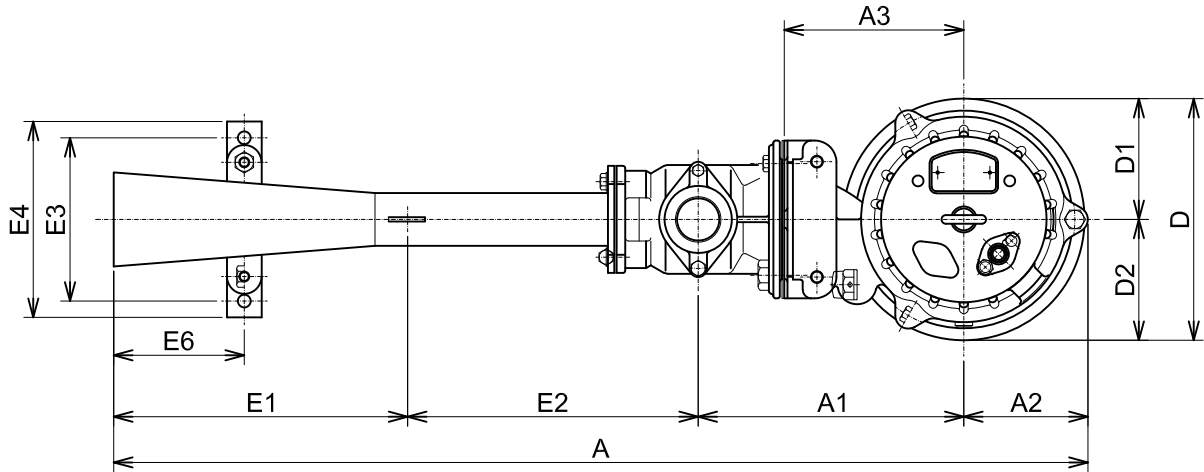

C.W.L. : Continuous running Water Level

DIMENSIONS:USCS (Inch)

Model	HP	Air-Inlet Dia.	Ejector Pump & Motor															C.W.L. W1	*Wt. (lbs.)
			A	A1	A2	A3	B	D	D1	D2	H	E1	E2	E3	E4	E5	E6		
15-BER3	2	1 1/4"	35 1/4	95/8	4 1/2	6 1/2	8 7/8	8 3/4	4 3/8	4 3/8	22 1/8	10 5/8	10 1/2	5 7/8	7 1/16	6 5/16	4 3/4	19 1/4	95

DIMENSIONS:METRIC (mm)

Model	kW	Air-Inlet Dia.	Ejector Pump & Motor															C.W.L. W1	*Wt. (kg)
			A	A1	A2	A3	B	D	D1	D2	H	E1	E2	E3	E4	E5	E6		
15-BER3	1.5	32	895	244	114	165	225	222	111	111	562	270	267	150	180	160	120	490	43

*Excluding Cable