

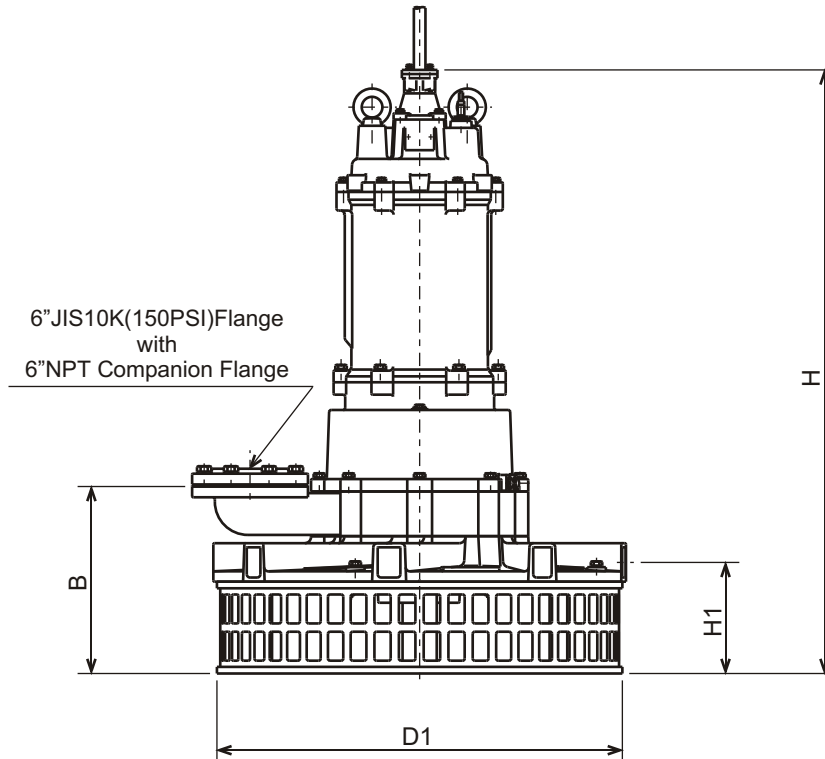

**TRN - SERIES
SUBMERSIBLE - AERATOR**

DIMENSIONS

150TRN440-63

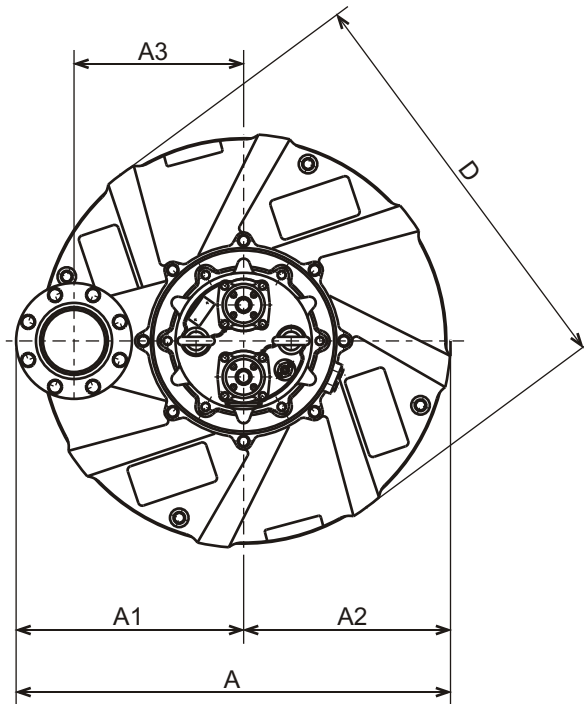

DIMENSIONS:USCS (In ch)

Model	HP	Air-Inlet Dia.	Aerator & Motor									*Wt. (lbs.)
			A	A1	A2	A3	B	D	D1	H	H1	
150TRN440-63	54	6"	41 5/16	21 5/8	19 11/16	16 1/8	17 13/16	39 3/8	38 9/16	57 7/16	10 9/16	1280

DIMENSIONS:METRIC (mm)

Model	kW	Air-Inlet Dia.	Aerator & Motor									*Wt. (kg)
			A	A1	A2	A3	B	D	D1	H	H1	
150TRN440-63	40	150	1050	550	500	410	452	1000	980	1459	269	583

*Excluding Cable