

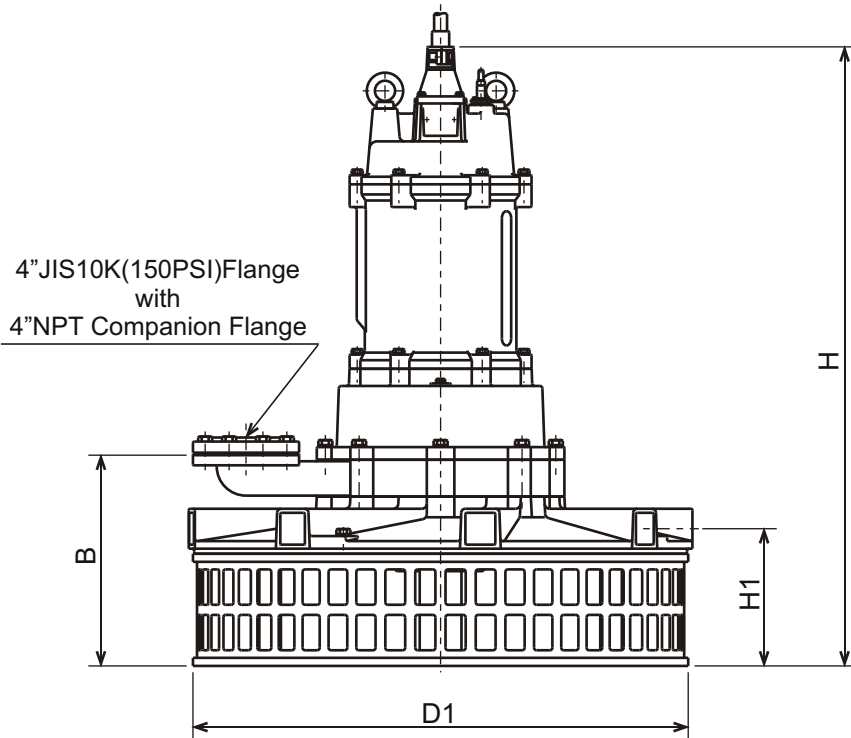

**TRN - SERIES
SUBMERSIBLE - AERATOR**

DIMENSIONS

100TRN424-64

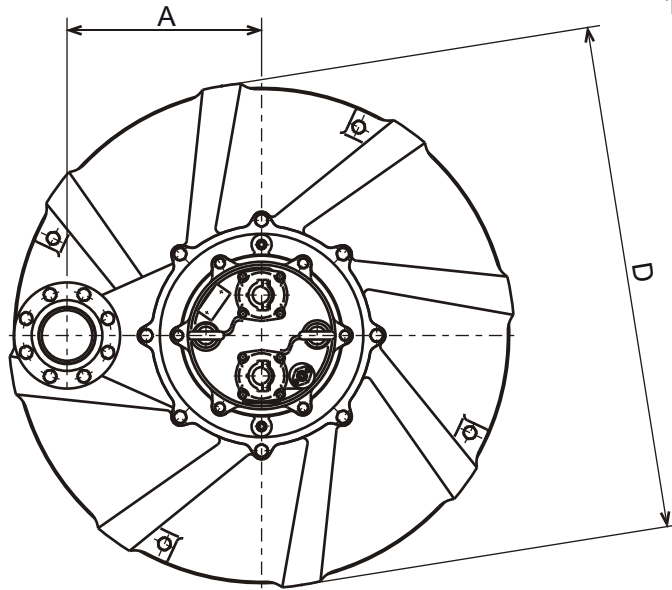

DIMENSIONS:USCS (Inch)

Model	HP	Air-Inlet Dia.	Aerator & Motor						*Wt. (lbs.)
			A	B	D	D1	H	H1	
100TRN424-64	32	4"	15 3/16	16 7/16	39 3/8	38 9/16	48 1/4	10 11/16	960

*Excluding Cable

DIMENSIONS:METRIC (mm)

Model	kW	Air-Inlet Dia.	Aerator & Motor						*Wt. (kg)
			A	B	D	D1	H	H1	
100TRN424-64	24	100	385	417	1000	980	1225	272	435