

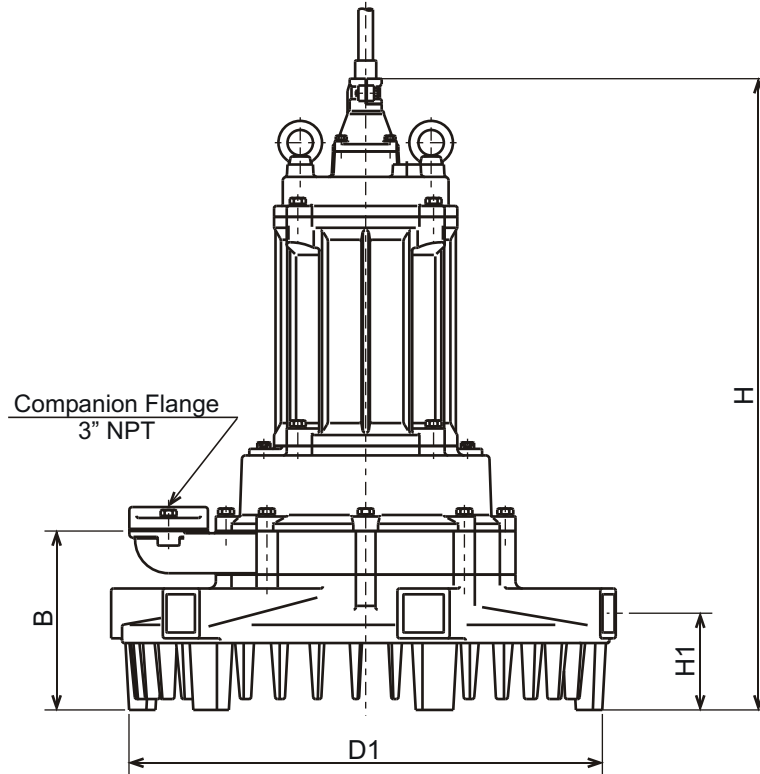

**TRN - SERIES
SUBMERSIBLE - AERATOR**

DIMENSIONS

80TRN47.5-62

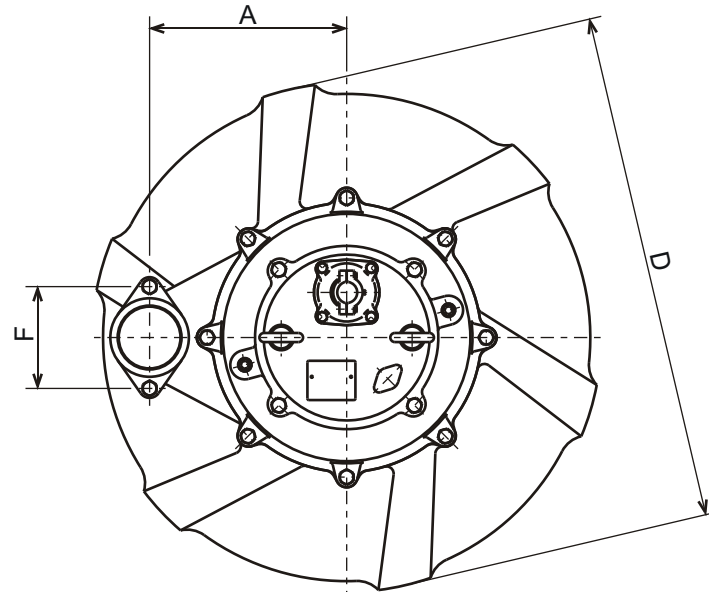

DIMENSIONS:USCS (Inch)

Model	HP	Air-Inlet Dia.	Aerator & Motor							*Wt. (lbs.)
			A	B	F	D	D1	H	H1	
80TRN47.5-62	10	3"	10 11/16	9 11/16	5 1/2	27 9/16	26	34 3/16	5 1/4	419

DIMENSIONS:METRIC (mm)

Model	kW	Air-Inlet Dia.	Aerator & Motor							*Wt. (kg)
			A	B	F	D	D1	H	H1	
80TRN47.5-62	7.5	80	271	246	140	700	660	868	133	190

*Excluding Cable