

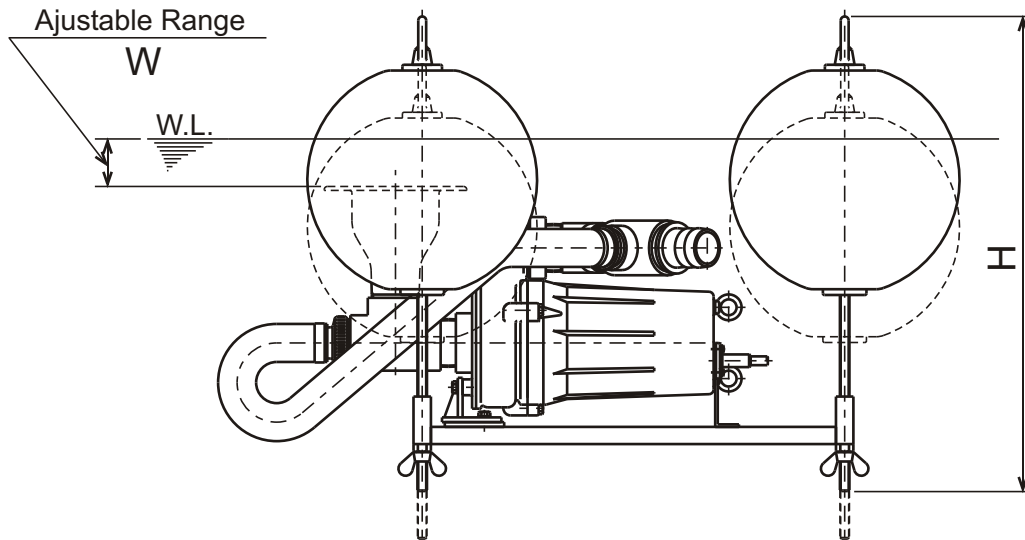

FSP - SERIES
SCUM SKIMMER PUMP

DIMENSIONS

8-FSP3

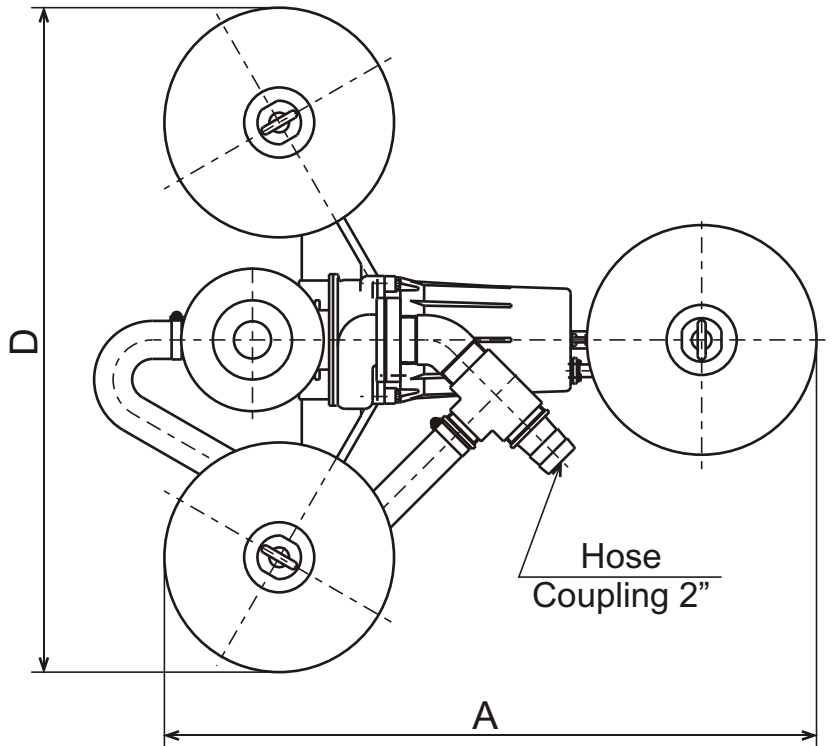

DIMENSIONS:USCS (Inch)

Model	HP	NOM. SIZE	Pump & Motor			Ajustable Range	Wt. (lbs.)
			A	D	H	W	
8-FSP3	1	2"	32 7/16	33 1/16	23 5/8	0 - 2 3/8	84

*Excluding Cable

DIMENSIONS:METRIC (mm)

Model	kW	NOM. SIZE	Pump & Motor			Ajustable Range	Wt. (kg)
			A	D	H	W	
8-FSP3	0.75	50	824	839	600	0 - 60	38