

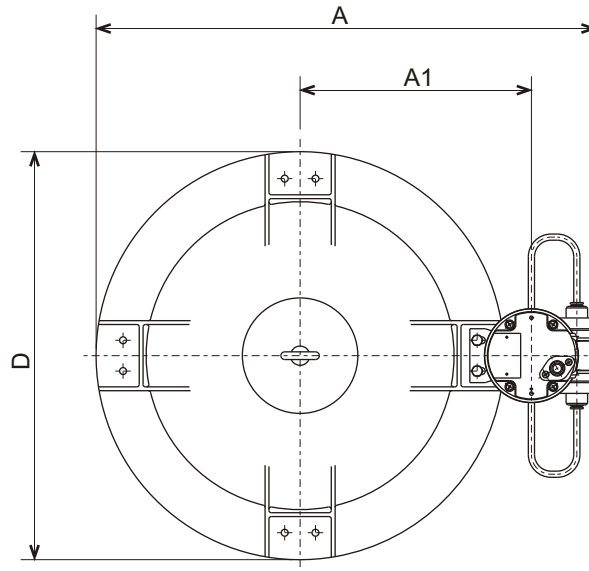

**FHP - SERIES
FLOATING - DECANTER PUMP**

DIMENSIONS



FHP4-8T

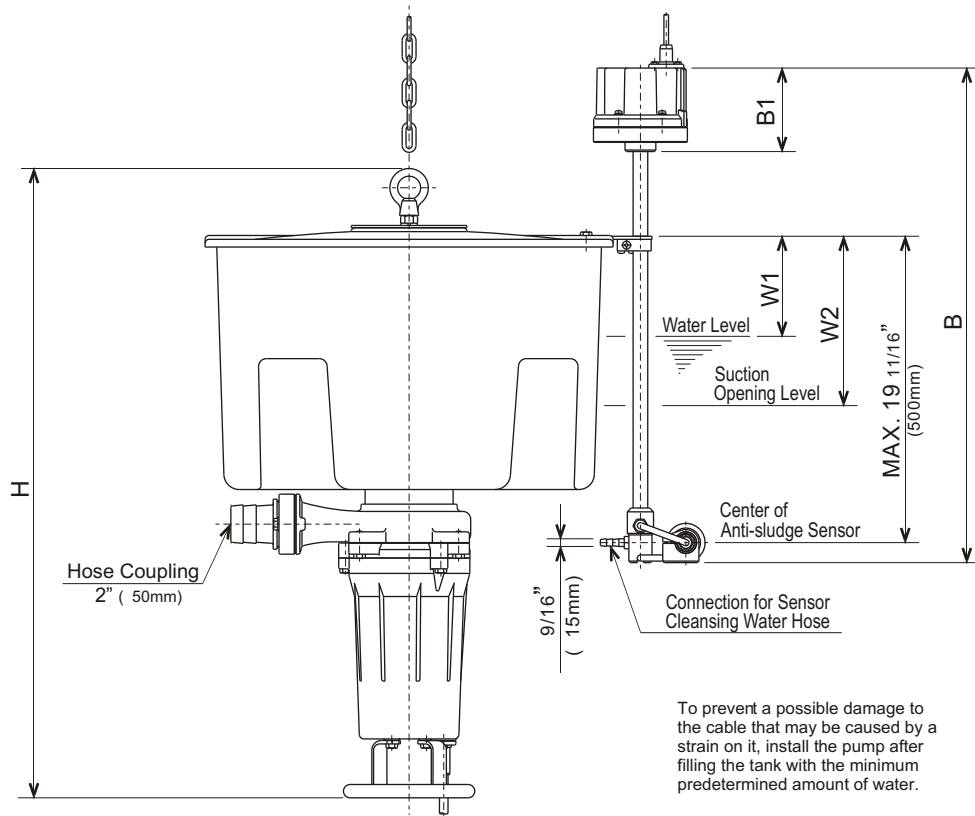

To prevent a possible damage to the cable that may be caused by a strain on it, install the pump after filling the tank with the minimum predetermined amount of water.

DIMENSIONS:USCS (Inch)

Model	HP	Nominal Dia.	Pump & Motor						Water Level		*Wt. (lbs.)
			A	A1	B	B1	D	H	W1	W2	
FHP4-8T	1	2"	25 9/16	11 7/8	25 5/16	4 5/16	20 7/8	32 3/16	5 1/8	8 5/8	62

DIMENSIONS:METRIC (mm)

Model	kW	Nominal Dia.	Pump & Motor						Water Level		*Wt. (kg)
			A	A1	B	B1	D	H	W1	W2	
FHP4-8T	0.75	50	650	301	643	109	530	818	130	220	28

*Excluding Cable