

8-FSPS

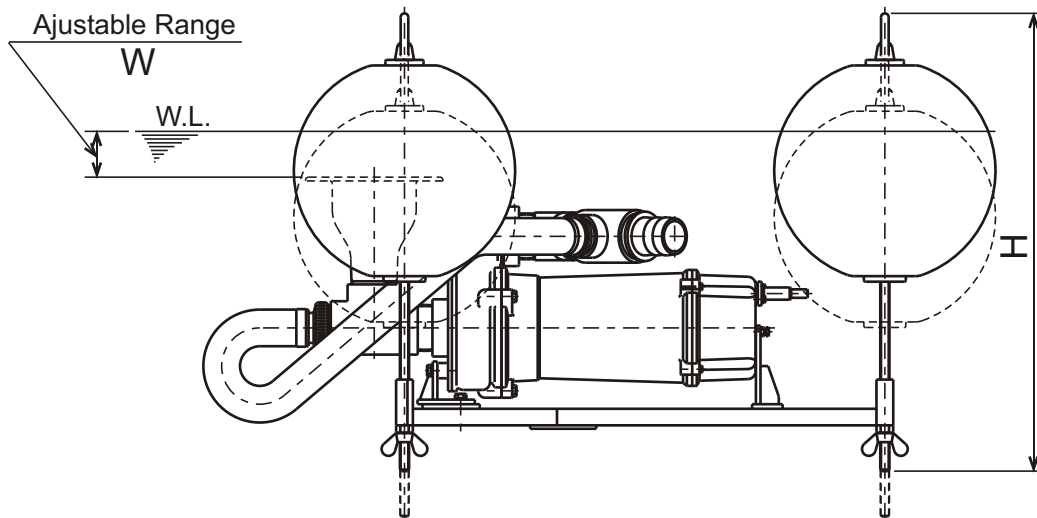
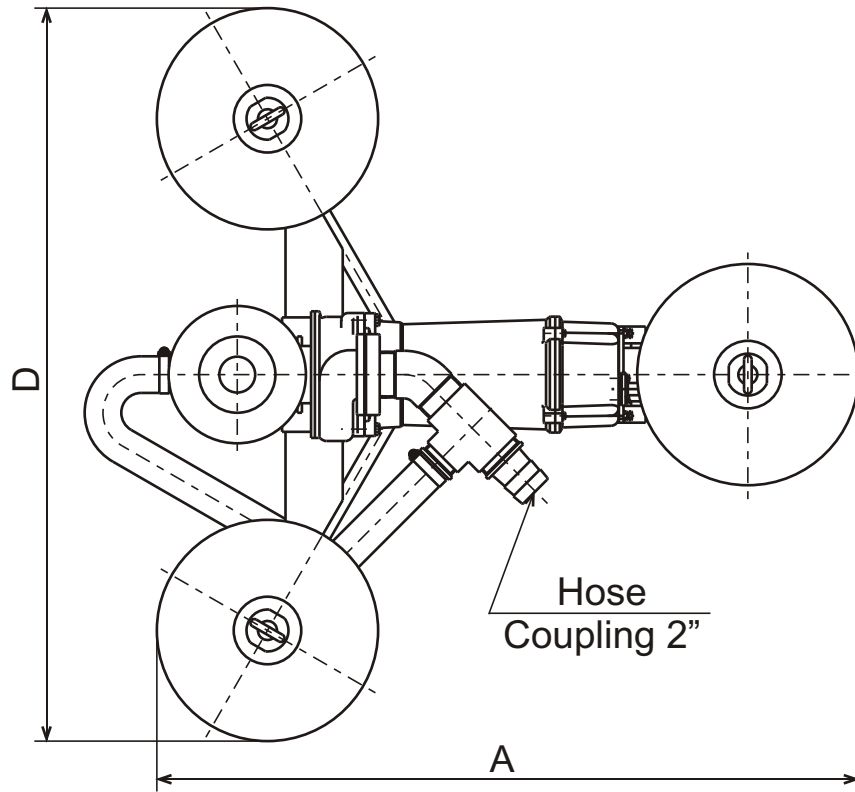

DIMENSIONS:USCS (Inch)

Model	HP	NOM. SIZE	Pump & Motor			Ajustable Range	Wt. (lbs.)
			A	D	H	W	
8-FSPS	1	2"	36 1/4	37 13/16	23 5/8	0 - 2 3/8	99

*Excluding Cable

DIMENSIONS:METRIC (mm)

Model	kW	NOM. SIZE	Pump & Motor			Ajustable Range	Wt. (kg)
			A	D	H	W	
8-FSPS	0.75	50	920	961	600	0 - 60	45