

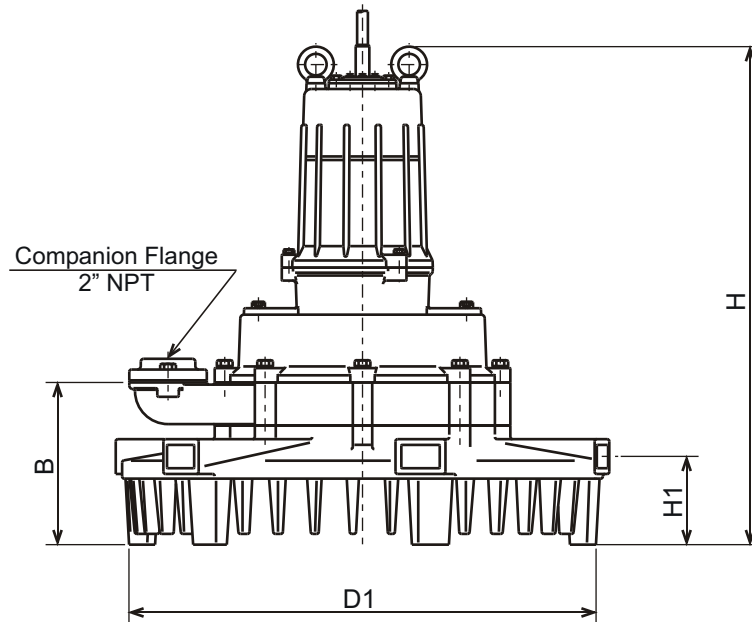

**TRN - SERIES
SUBMERSIBLE - AERATOR**

DIMENSIONS

50TRN43.7-62

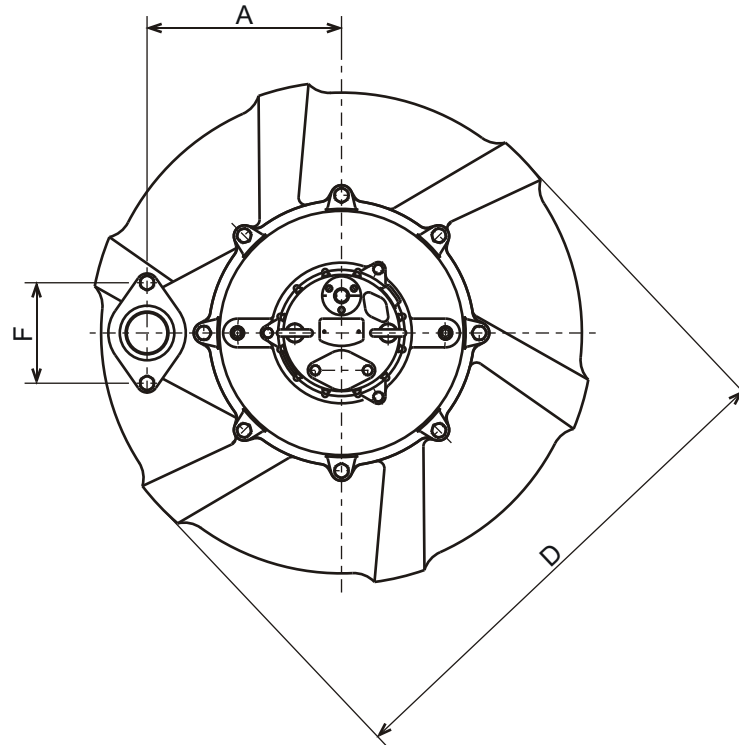

DIMENSIONS:USCS (Inch)

Model	HP	Air-Inlet Dia.	Aerator & Motor							*Wt. (lbs.)
			A	B	F	D	D1	H	H1	
50TRN43.7-62	5	2"	10 11/16	8 7/8	5 1/2	27 9/16	26	27 5/16	4 13/16	331

*Excluding Cable

DIMENSIONS:METRIC (mm)

Model	kW	Air-Inlet Dia.	Aerator & Motor							*Wt. (kg)
			A	B	F	D	D1	H	H1	
50TRN43.7-62	3.7	50	271	226	140	700	660	694	123	150