

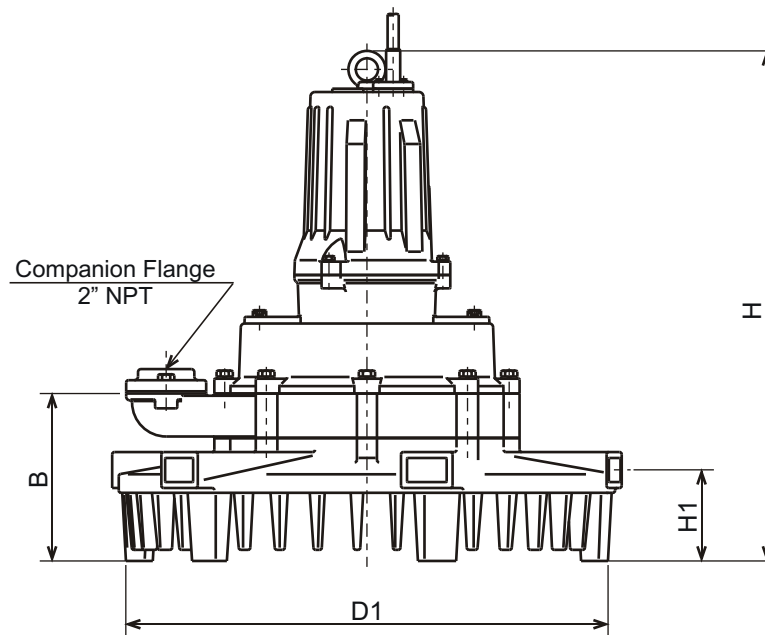

**TRN - SERIES
SUBMERSIBLE - AERATOR**

DIMENSIONS

50TRN42.2-62

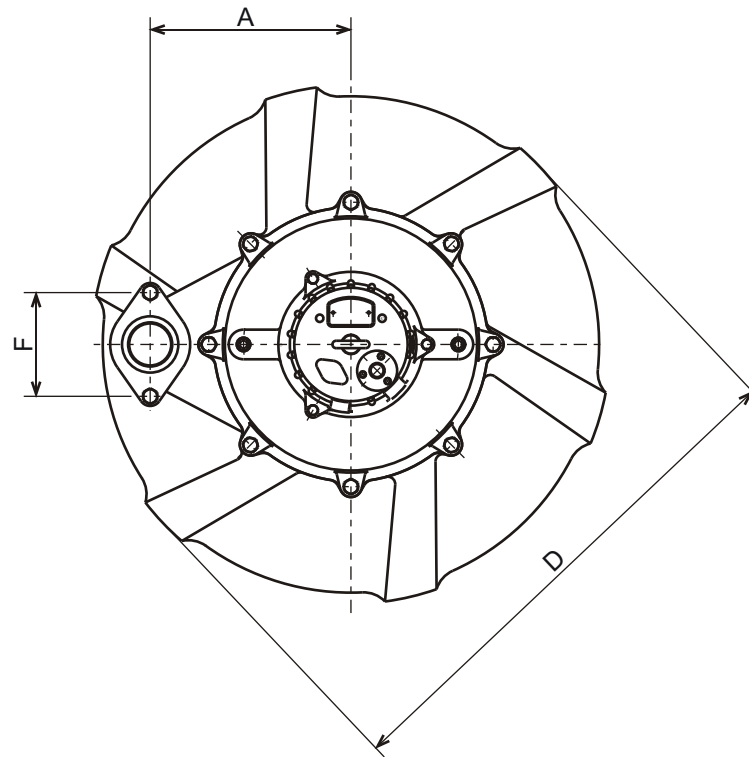

DIMENSIONS:USCS (Inch)

Model	HP	Air-Inlet Dia.	Aerator & Motor							*Wt. (lbs.)
			A	B	F	D	D1	H	H1	
50TRN42.2-62	3	2"	10 11/16	8 7/8	5 1/2	27 9/16	26	27 1/8	4 13/16	309

DIMENSIONS:METRIC (mm)

Model	kW	Air-Inlet Dia.	Aerator & Motor							*Wt. (kg)
			A	B	F	D	D1	H	H1	
50TRN42.2-62	2.2	50	271	226	140	700	660	689	123	140

*Excluding Cable