

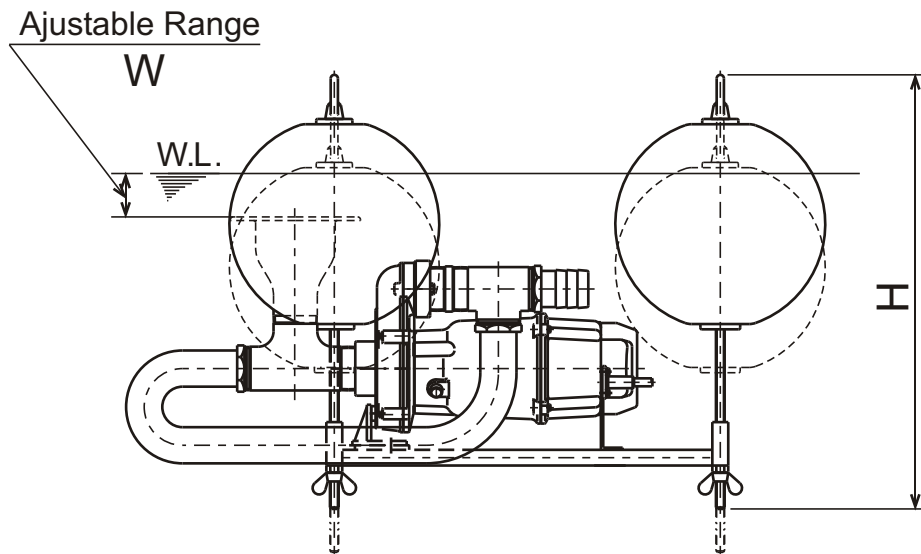

**FSP - SERIES**  
**SCUM SKIMMER PUMP**

**DIMENSIONS**

**4-FSPS2**

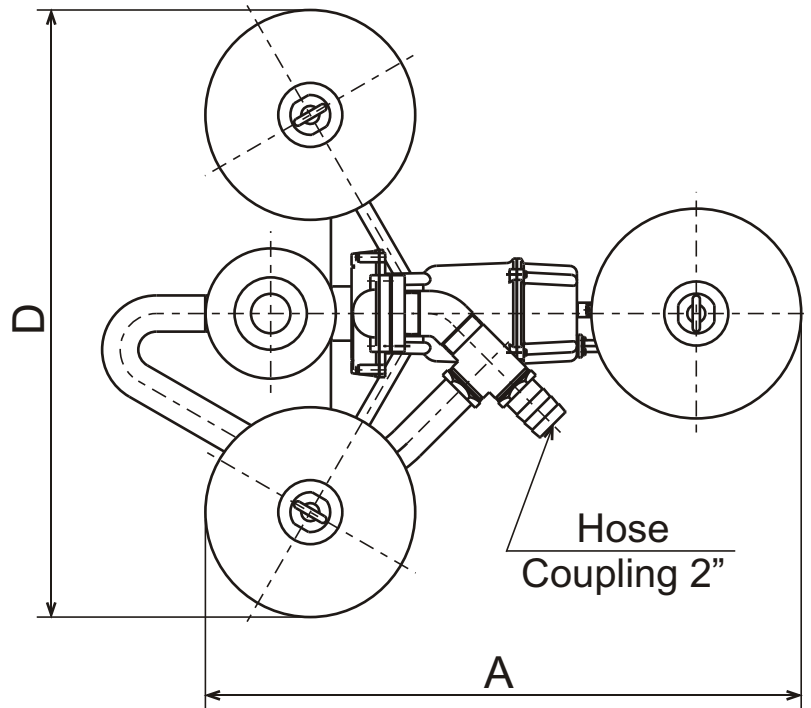

**DIMENSIONS:USCS (Inch)**

Model	HP	NOM. SIZE	Pump & Motor			Ajustable Range	Wt. (lbs.)
			A	D	H	W	
4-FSPS2	1/2	2"	32 7/16	33 1/16	23 5/8	0 - 2 3/8	84

\*Excluding Cable

**DIMENSIONS:METRIC (mm)**

Model	kW	NOM. SIZE	Pump & Motor			Ajustable Range	Wt. (kg)
			A	D	H	W	
4-FSPS2	0.40	50	824	839	600	0 - 60	38