

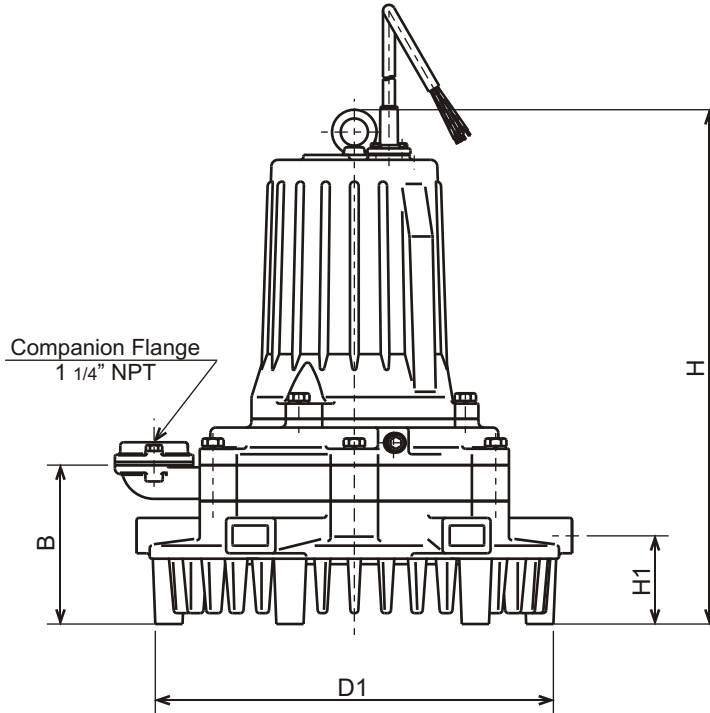

**TRN - SERIES
SUBMERSIBLE - AERATOR**

DIMENSIONS

**32TRN2.75-62
32TRN21.5-62**

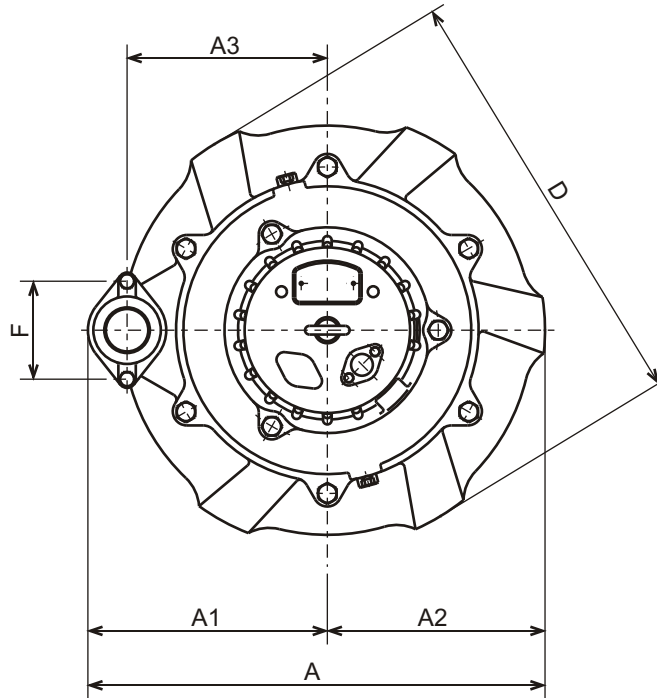

DIMENSIONS:USCS (Inch)

Model	HP	Air-Inlet Dia.	Aerator & Motor										*Wt. (lbs.)
			A	A1	A2	A3	B	F	D	D1	H	H1	
32TRN2.75-62	1	1 1/4"	16 9/16	8 11/16	7 7/8	7 1/4	5 3/4	3 9/16	15 3/4	14 5/8	18 5/8	3 3/16	121
32TRN21.5-62	2	1 1/4"	16 9/16	8 11/16	7 7/8	7 1/4	5 3/4	3 9/16	15 3/4	14 5/8	18 5/8	3 3/16	121

DIMENSIONS:METRIC (m.m)

Model	kW	Air-Inlet Dia.	Aerator & Motor										*Wt. (kg)
			A	A1	A2	A3	B	F	D	D1	H	H1	
32TRN2.75-62	0.75	32	420	220	200	184	146	90	400	371	473	81	55
32TRN21.5-62	1.5	32	420	220	200	184	146	90	400	371	473	81	55

*Excluding Cable