

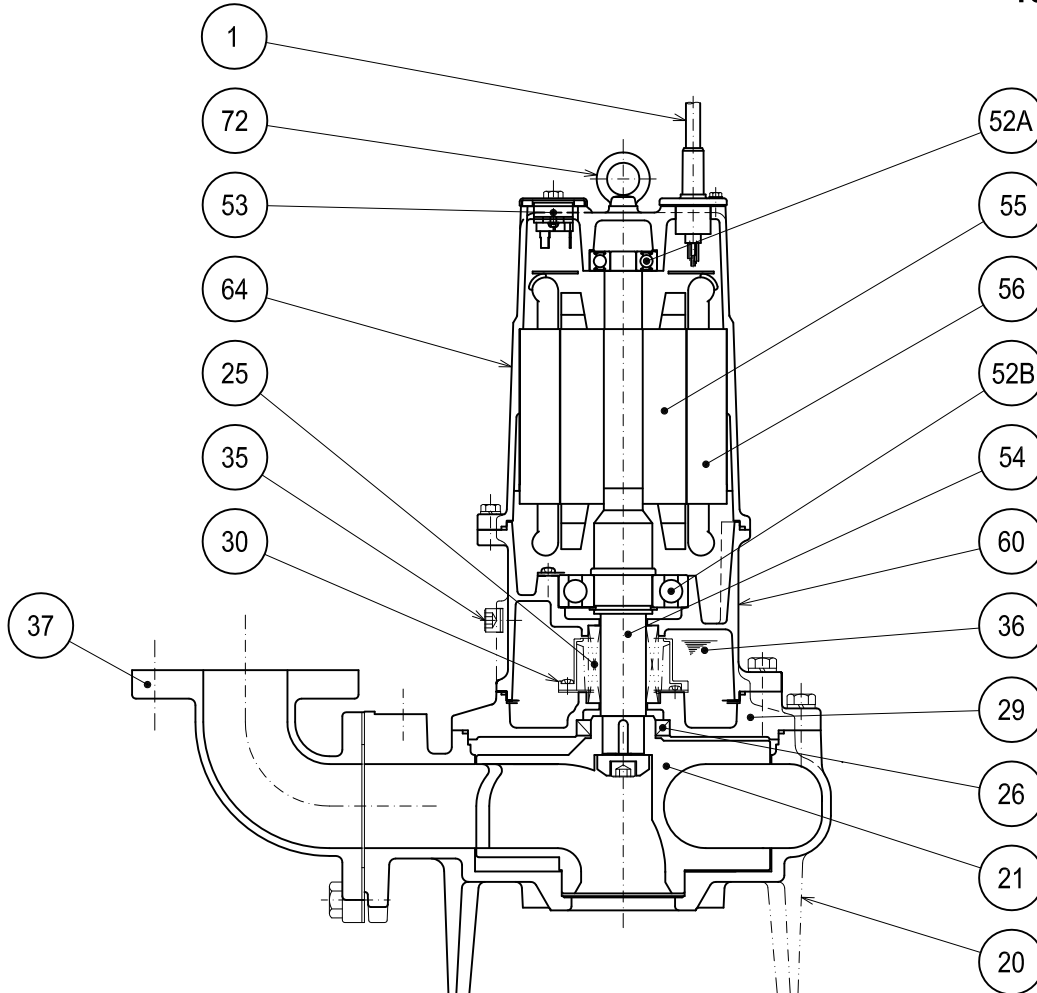

**BZ-SERIES**  
**SEWAGE & WASTEWATER PUMPS**

**SECTIONAL VIEW**

**100BZ41.5 -62**  
**100BZ42.2 -62**  
**100BZ43.7 -62**



	BZ41.5	BZ42.2	BZ43.7
* 1	AWG 16/4-32ft	AWG 14/4-32ft	AWG 12/4-32ft
* 2	H-30A	H-30A	H-35A
* 3	TC456812	TC456812	TC507212
* 4	#6307ZZC3	#6307ZZC3	#6309ZZC3

PART#	DESCRIPTION	MAIN MATERIAL / NOTE	RELATED ASTM,AISI CODE	RELATED EN CODE	QTY
1	Power Cable	PVC Sheath * 1			1
20	Pump Casing	Cast Iron	A48M Class30B	EN 1561 GJL-200	1
21	Impeller	Cast Iron	A48M Class30B	EN 1561 GJL-200	1
25	Mechanical Seal	Silicon Carbide / * 2			1
26	Oil Seal	NBR / * 3			1
29	Oil Casing	Cast Iron	A48M Class30B	EN 1561 GJL-200	1
30	Oil Lifter	PBT Plastic W/(GF+MD)40			1
35	Oil Plug	Stainless Steel	S 30400	1.4301	1
36	Lubricant	Turbine Oil ISO VG32 or SAE 10W-20			
37	Discharge Bend	Cast Iron / 4"ANSI Flange(150PSI)	A48M Class30B	EN 1561 GJL-200	1
52A	Upper Bearing	AC-#6304ZZC3			1
52B	Lower Bearing	* 4			1
53	Motor Protector				1
54	Shaft	Stainless Steel	S 42000	1.4028	1
55	Rotor				1
56	Stator				1
60	Bearing Housing	Cast Iron	A48M Class30B	EN 1561 GJL-200	1
64	Motor Housing	Cast Iron	A48M Class30B	EN 1561 GJL-200	1
72	Lifting Lug Bolt	Stainless Steel	S 30400	1.4301	2