

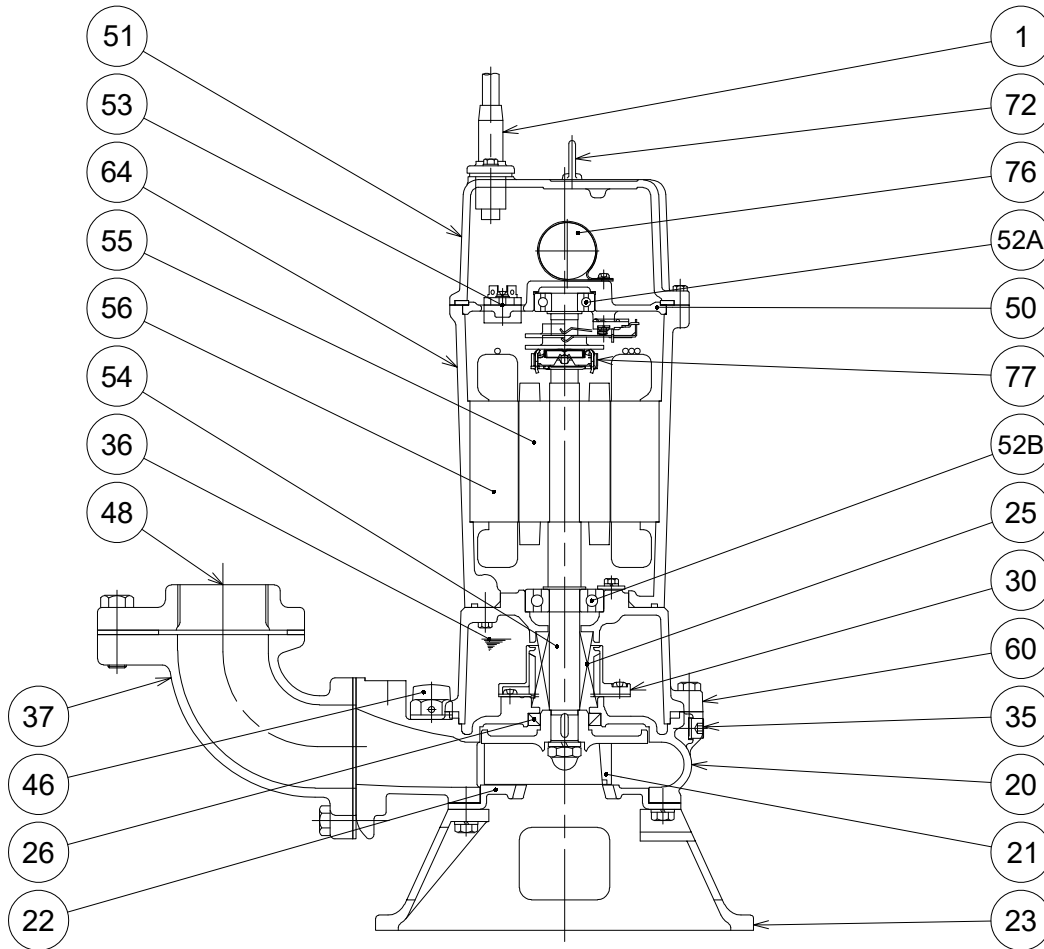

**50C2.75S-CR -63**



PART#	DESCRIPTION	MAIN MATERIAL / NOTE	RELATED ASTM, AISI CODE	RELATED EN CODE	QTY
1	Power Cable	PVC Sheath AWG 16/3-20ft			1
20	Pump Casing	Cast Iron	A48M Class30B	EN 1561 GJL-200	1
21	Impeller	Cast Iron W/Tungsten Carbide	A48M Class30B	EN 1561 GJL-200	1
22	Suction Cover	High Chrome Cast Iron	A532 ClassIII TypeA	DIN 1695 G-X260Cr27	1
23	Strainer Stand	Cast Iron	A48M Class30B	EN 1561 GJL-200	1
25	Mechanical Seal	Silicon Carbide / H-20			1
26	Oil Seal	NBR / TC32488			1
30	Oil Lifter	PBT Resin W/GF40			1
35	Oil Plug	Stainless Steel	S 30400	1.4301	1
36	Lubricant	Turbine Oil ISO VG32 or SAE10W-20			
37	Discharge Bend	Cast Iron	A48M Class30B	EN 1561 GJL-200	1
46	Air Valve	Nylon			1
48	Companion Flange	Cast Iron / NPT 2"	A48M Class30B	EN 1561 GJL-200	1
50	Motor Bracket	Cast Iron	A48M Class30B	EN 1561 GJL-200	1
51	Head Cover	Cast Iron	A48M Class25B	EN 1561 GJL-150	1
52A	Upper Bearing	#6203ZZC3			1
52B	Lower Bearing	#6304ZZC3			1
53	Motor Protector				1
54	Shaft	Stainless Steel	S 42000	1.4028	1
55	Rotor				1
56	Stator				1
60	Bearing Housing	Cast Iron	A48M Class25B	EN 1561 GJL-150	1
64	Motor Housing	Cast Iron	A48M Class25B	EN 1561 GJL-150	1
72	Lifting Lug Bolt	Stainless Steel	S 30400	1.4301	2
76	Capacitor				1
77	Centrifugal Switch				1