

200C615-CR -61

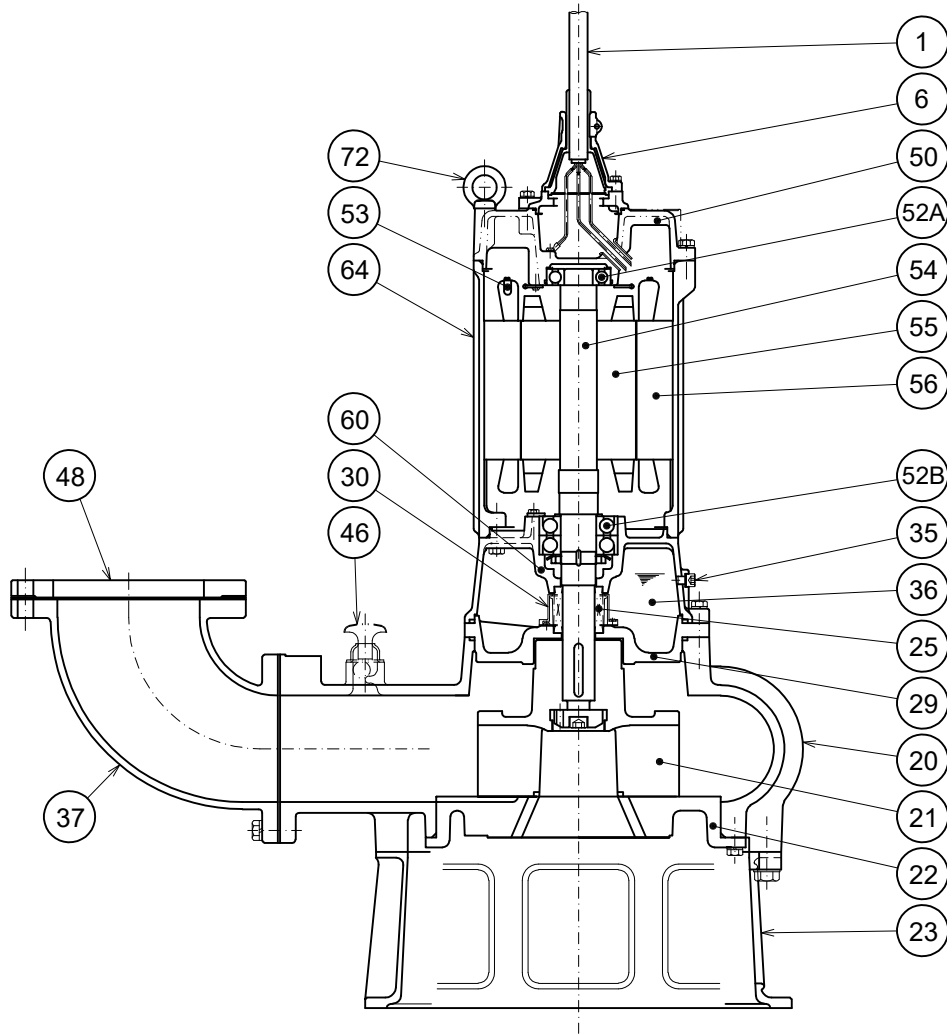

PART#	DESCRIPTION	MAIN MATERIAL / NOTE	RELATED ASTM,AISI CODE	RELATED EN CODE	QTY
1	Power Cable	Chloroprene Sheath AWG 6/4, 14/2-32ft			1
6	Stuffing Box	Cast Iron	A48M Class30B	EN 1561 GJL-200	1
20	Pump Casing	Cast Iron	A48M Class30B	EN 1561 GJL-200	1
21	Impeller	High Chrome Cast Iron W/Tungsten Carbide	A532 Class III TypeA	DIN 1695 G-X260Cr27	1
22	Suction Cover	High Chrome Cast Iron	A532 Class III TypeA	DIN 1695 G-X260Cr27	1
23	Pump Stand	Malleable Cast Iron	A47 Grade 32510	EN 1562 GJMB-350-10	1
25	Mechanical Seal	Silicon Carbide / H-45			1
29	Oil Casing	Cast Iron	A48M Class30B	EN 1561 GJL-200	1
30	Oil Lifter	PBT Resin W/GF40			1
35	Oil Plug	Stainless Steel	S 30400	1.4301	2
36	Lubricant	Turbine Oil ISO VG32 or SAE 10W-20			
37	Discharge Bend	Cast Iron	A48M Class30B	EN 1561 GJL-200	1
46	Air Release Valve	Steel (Cold Rolled)	A109/A1008	EN 10130	1
48	Welded Flange	Steel / 8"	A283 Grade D	EN 10025 S275	1
50	Motor Bracket	Cast Iron	A48M Class30B	EN 1561 GJL-200	1
52A	Upper Bearing	AC-#6308ZZC3			1
52B	Lower Bearing	#6310ZZD2C3			1
53	Motor Protector				3
54	Shaft	Stainless Steel	S 42000	1.4028	1
55	Rotor				1
56	Stator				1
60	Bearing Housing	Cast Iron	A48M Class30B	EN 1561 GJL-200	1
64	Motor Housing	Cast Iron	A48M Class30B	EN 1561 GJL-200	1
72	Lifting Lug Bolt	Steel	A283 Grade D	EN 10025 S275	3