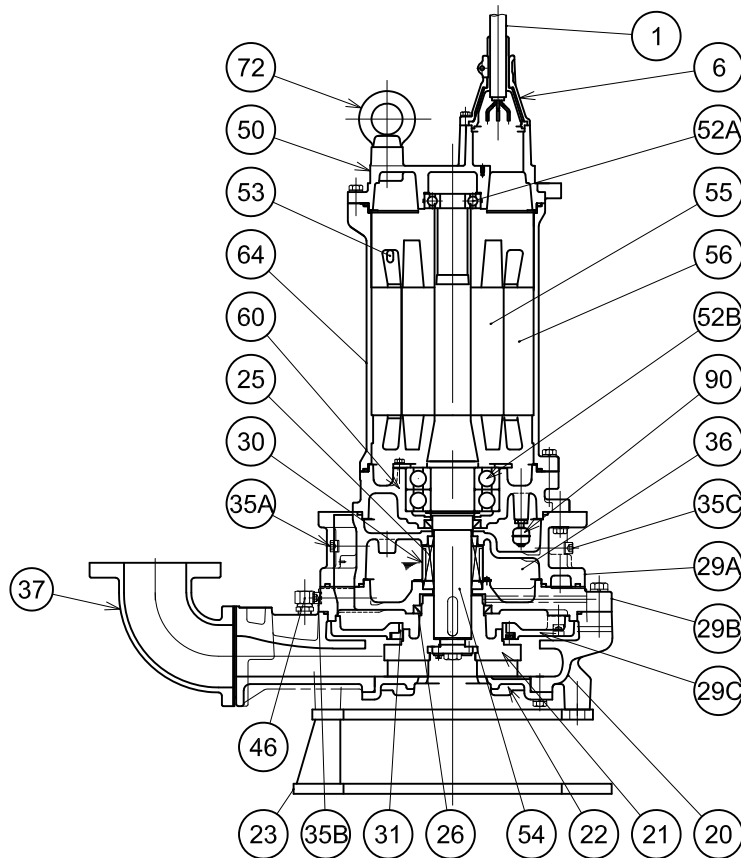

**TSURUMI PUMP****C-SERIES
CUTTER - TYPE - SEWAGE & WASTEWATER PUMPS****SECTIONAL VIEW****100C222-CR -61**

PART#	DESCRIPTION	MAIN MATERIAL / NOTE	ASTM, AISI CODE	RELATED DIN CODE	QTY
1	Power Cable	Chloroprene Sheath AWG6/4-32ft			1
	Power Cable	Chloroprene Sheath AWG6/3-32ft			1
	Control Cable	Chloroprene Sheath AWG16/4-32ft			1
6	Stuffing Box	Cast Iron	A48M Class30B	EN 1561 GJL-200	2
20	Pump Casing	Cast Iron	A48M Class30B	EN 1561 GJL-200	1
21	Impeller	High Chrome Cast Iron W/Tungsten Carbide	A532 ClassIII TypeA	DIN 1695 G-X260Cr27	1
22	Suction Cover	High Chrome Cast Iron	A532 ClassIII TypeA	DIN 1695 G-X260Cr27	1
23	Pump Stand	Steel	A283 Grade D	EN 10025 S275	1
25	Mechanical Seal	Silicon Carbide / H-60			1
26	Oil Seal	NBR / TC10012513			1
29A	Casing Cover	Cast Iron	A48M Class30B	EN 1561 GJL-200	1
29B	Oil Casing	Cast Iron	A48M Class30B	EN 1561 GJL-200	1
29C	Casing Plate	Cast Iron	A48M Class30B	EN 1561 GJL-200	1
30	Oil Lifter	Steel (Cold Rolled)	A109/A1008	EN 10130	1
31	Wear Ring	Stainless Steel Casting	A743 CF-8M	GX5CrNiMo19-11-2	1
35A	Oil Plug	Stainless Steel	S 30400	1.4301	2
35B	Oil Plug	Stainless Steel	S 30400	1.4301	1
35C	Drain Plug	Stainless Steel	S 30400	1.4301	1
36	Lubricant	Turbine Oil ISO VG32 or SAE10W-20			1
37	Discharge Bend	Cast Iron	A48M Class30B	EN 1561 GJL-200	1
46	Air Release Valve	Stainless Steel	S 30400	1.4301	1
50	Motor Bracket	Cast Iron	A48M Class30B	EN 1561 GJL-200	1
52A	Upper Bearing	#6308ZZC3			1
52B	Lower Bearing	#6314ZZD2C3			1
53	Motor Protector				3
54	Shaft	Stainless Steel	S 42000	1.4028	1
55	Rotor				1
56	Stator				1
60	Bearing Housing	Cast Iron	A48M Class30B	EN 1561 GJL-200	1
64	Motor Housing	Cast Iron	A48M Class30B	EN 1561 GJL-200	1
72	Lifting Lug Bolt	Stainless Steel	S 30400	1.4301	2
90	Leak Sensor (Float)				1