

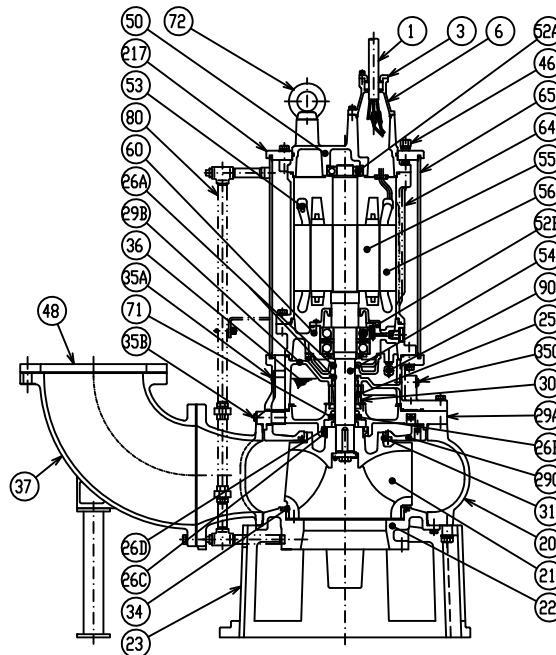

**B-SERIES**  
**SEWAGE & WASTEWATER PUMPS**

**SECTIONAL VIEW**



**300BK630 -63**  
**350BK630 -63**

PART#	DESCRIPTION	MAIN MATERIAL / NOTE	RELATED ASTM,AISI CODE	RELATED EN CODE	QTY
1	Power Cable	Chloroprene Sheath AWG 4/4-32ft			1
	Power Cable	Chloroprene Sheath AWG 4/3-32ft			1
	Control Cable	Chloroprene Sheath AWG 16/4-32ft			1
3	Gland	Cast Iron	A48M Class30B	EN 1561 GJL-200	2
6	Stuffing Box	Cast Iron	A48M Class30B	EN 1561 GJL-200	2
20	Pump Casing	Cast Iron	A48M Class35B	EN 1561 GJL-250	1
21	Impeller	Cast Iron	A48M Class35B	EN 1561 GJL-250	1
22	Suction Cover	Cast Iron	A48M Class35B	EN 1561 GJL-250	1
23	Suction Strainer	Ductile Cast Iron	A536 80-55-06	EN 1563 GJS-500-7	1
25	Mechanical Seal	Silicon Carbide / H-60			1
26A	Oil Seal	NBR / TC60789			2
26B	Oil Seal	NBR / TC709513			1
26C	Oil Seal	NBR / TC11014014			1
26D	Labyrinth ring	Stainless Steel	S 30400	1.4301	1
29	Oil Casing	Cast Iron	A48M Class35B	EN 1561 GJL-250	1
29A	Casing Cover	Cast Iron	A48M Class35B	EN 1561 GJL-250	1
29B	Casing Plate	Cast Iron	A48M Class35B	EN 1561 GJL-250	1
30	Oil Lifter	Steel (Cold Rolled )	A109/A1008	EN 10130	1
31	Wear Ring	Cast Iron	A48M Class35B	EN 1561 GJL-250	1
34	Mouth Ring	Cast Iron	A48M Class35B	EN 1561 GJL-250	1
35A	Oil Plug	Stainless Steel	S 30400	1.4301	2
35B	Oil Plug	Stainless Steel	S 30400	1.4301	1
35C	Drain Plug	Stainless Steel	S 30400	1.4301	1
36	Lubricant	Turbine Oil ISO VG32 or SAE 10W-20			
37	Discharge Bend	Cast Iron	A48M Class30B	EN 1561 GJL-200	1
46	Air Release Valve	Stainless Steel	S 30400	1.4301	1
48	Welded Flange	Cast Iron / 12" or 14"	A48M Class30B	EN 1561 GJL-200	1
50	Motor Bracket	Cast Iron	A48M Class30B	EN 1561 GJL-200	1
52A	Upper Bearing	#6310ZZC3			1
52B	Lower Bearing	#7314BDB			1
53	Motor Protector				3
54	Shaft	Stainless Steel	S 42000	1.4021	1
55	Rotor				1
56	Stator				1
60	Bearing Housing	Cast Iron	A48M Class30B	EN 1561 GJL-200	1
64	Motor Housing	Cast Iron	A48M Class30B	EN 1561 GJL-200	1
65	Outer Cover	Steel Pipe (& Steel)	A53 Type F (& A283 Grade D)	DIN 1615 St 33 (& EN 10025 S275)	1
71	Shaft Sleeve	Stainless Steel	S 30400	1.4301	1
72	Lifting Lug Bolt	Stainless Steel	S 30400	1.4301	2
80	Cooling Pipe Set	Steel	A283 Grade D	EN 10025 S275	1
90	Leak Sensor (Float)				1
217	Fixing Plate	Cast Iron	A48M Class30B	EN 1561 GJL-200	1