

PARTS LIST		SEWAGE & WASTEWATER PUMPS			3/26/2013	
ITEM	PART No.	DESCRIPTION	QTY	SIZE	MATERIAL	NOTES
1	001-938-12	Cabtyre Cable Set (8m)220V-60Hz	1	2PNCT4Cx5.5mm2	KR-2	
	001-938-12	Cabtyre Cable Set (8m)380/440/460V-60Hz	1	2PNCT4Cx5.5mm2	KR-2	
	001-938-12	Cabtyre Cable Set (8m)380/400/415V-50Hz	1	2PNCT4Cx5.5mm2	KR-2	
2	140-055-10	Hex.Bolt	4	M8x25	SUS304	
3	142-163-18	Spring Washer	4	M8	SUS304	
4	070-107-18	Cable Clamp	1		FC	
5	140-035-14	Hex.Bolt	2	M6x20	SUS304	
6	006-126-14	Stuffing Box	1	No.2	FC	
7	008-143-13	Mould Cover	1	KR2-8	CR	
8	143-085-21	Pan Screw (w/Spring Washer)	1	M4x6	SWRM	
9	009-130-10	Terminal	1	R-5.5-4	CU	
10	009-276-19	Compression type Terminal 220V-60Hz	3	TMNB-5.5(Insulated)		
	009-276-19	Compression type Terminal 380/440/460V-60Hz	3	TMNB-5.5(Insulated)		
	009-276-19	Compression type Terminal 380/400/415V-50Hz	3	TMNB-5.5(Insulated)		
11	072-107-14	Eye Bolt	2	M16	SS	
	142-399-15	Washer		d17xd29x0.1t	SUS304	
	142-400-10	Washer		d17xd29x0.3t	SUS304	
12	140-098-15	Hex.Bolt	4	M12x35	SUS304	
13	142-165-10	Spring Washer	4	M12	SUS304	
14	050-000-79	Motor Bracket	1		FC	
15	122-173-19	O-Ring	1	V-225(222.5xd6)	NBR	
16	142-000-08	Wave Washer	1	6306B(d71xd59x4.0t)	SK5	
17	052-000-25	Bearing (w/O-ring)	1	AC-6306ZZC3		
18	058-000-09	Lead Wire Protection Plate	1	d86xd224x1.6t	SPHC	
19	143-126-12	Pan Screw (w/Spring Washer/Plain Washer)	2	M4x12	SWRM	
20	053-456-12	Motor Protector 220V-60Hz	1	KA314-HLBL00	(H.C)	
	053-485-10	Motor Protector 380/440/460V-60Hz	1	KA314-HKXL00	(H.C)	
	053-485-10	Motor Protector 380/400/415V-50Hz	1	KA314-HKXL00	(H.C)	
21	055-000-68	Rotor	1Set			
22	147-067-16	Impeller Key	1	10x8x32l	SUS420	
23	056C0119	Stator 220V-60Hz	1Set			
	056C0210	Stator 380/440/460V-60Hz	1Set			
	056C0210	Stator 380/400/415V-50Hz	1Set			
24	064-000-12	Motor Frame	1		FC	
25	140-100-11	Hex.Bolt	4	M12x45	SUS304	
26	142-165-10	Spring Washer	4	M12	SUS304	
27	122-173-19	O-Ring	1	V-225(222.5xd6)	NBR	
28	140-032-37	Hex.Bolt	3	M6x15	SWRM	
29	062-223-16	Bearing Fixing Plate	1	d92xd130x4.5t	SS	
30	052-112-10	Bearing	1	6309ZZC3		
31	146-027-11	Retaining Ring	1	C45	SK5	
32	140-104-15	Hex.Bolt	4	M12x65	SUS304	
33	142-165-10	Spring Washer	4	M12	SUS304	
34	060-430-12	Bearing Housing	1		FC	

PARTS LIST		SEWAGE & WASTEWATER PUMPS			3/26/2013	
ITEM	PART No.	DESCRIPTION	QTY	SIZE	MATERIAL	NOTES
35	121-247-12	Packing	2	d12.3xd18x2t	PE	
36	035-113-18	Oil Plug	2	M12x14	SUS304	
37	140-099-16	Hex.Bolt	2	M12x40	SUS304	
38	142-165-10	Spring Washer	2	M12	SUS304	
39	025-280-16	Mechanical Seal	1	H-35A	SIC+CCBN	
40	143-070-23	Pan Screw	2	M5x6	SWRM	
41	030-156-18	Oil Lifter	1	H-35(A)(T)	Resin	
42	143-070-10	Pan Screw	3	M5x6	SWRM	
43	030-150-12	Seal Stopper	1	H-35(A)(T)	SPCC	
44	122-159-19	O-Ring	1	G-280(279.3xd5.7)	NBR	
45	029-187-14	Oil Casing	1	100-5.5/7.5-4B2	FC	
46	122-159-19	O-Ring	1	G-280(279.3xd5.7)	NBR	
47	026-115-12	Oil Seal	1	TC-608212	NBR	
48	021-001-83	Impeller (50Hz)	1	200B47.5-54	FC	
48	021B5519	Impeller (60Hz)	1	200B47.5-64	FC	
49	144-530-16	Hex.Socket Set Screw	2	M6x15	SUS304	
50	142-202-10	Impeller Fixing Washer	1	d13xd50x15t	SUS304	
51	142-000-22	Spring Washer	1	M12(CP)	SUS304	
52	140-304-17	Hex.Socket Cap Bolt	1	M12x45	SUS304	
53	046-107-13	Air Release Valve	1	PT-1/2	Nylon	
54	020-689-14	Pump Casing	1	200-11-4B3	FC	
55	120-173-13	Packing (S.Cover)		d321xd348x0.5t	PE	
56	022-536-11	Suction Cover	1	200-11-4B2	FC	
57	142-165-10	Spring Washer	3	M12	SUS304	
58	140-097-14	Hex.Bolt	3	M12x30	SUS304	
59	023-289-19	Pump Stand	3	200-11-4B2	FCD	
60	142-165-10	Spring Washer	3	M12	SUS304	
61	140-097-14	Hex.Bolt	3	M12x30	SUS304	
62	142-165-10	Spring Washer	3	M12	SUS304	
63	140-103-14	Hex.Bolt	3	M12x60	SUS304	
64	121-165-28	Packing	1	JIS5Kx150mm	NR	
65	037-166-12	Discharge Bend	1	150x200mm	FC	
66	142-166-11	Spring Washer	8	M16	SUS304	
67	140-127-14	Hex.Bolt	8	M16x55	SUS304	
		<Guide rail rail fittings>				
57	142-165-10	Spring Washer	6	M12	SUS304	
58	140-097-14	Hex.Bolt	6	M12x30	SUS304	
	099-000-06	Guide Hook	1	TO-150x200	FCD	
	121-165-28	Packing	1	JIS5Kx150mm	NR	
	140-318-14	Hex.Socket Cap Bolt	8	M16x45	SUS304	
	091-108-14	Duck Foot Bend(JIS10K)	1	TO-200	FC	
	094-109-14	Guide Support	1	TO-150/250	FCD	
	140-099-16	Hex.Bolt	3	M12x40	SUS304	
	141-007-49	Hex.Nut	3	M12(H=7)	SUS304	

PARTS LIST		SEWAGE & WASTEWATER PUMPS			3/26/2013	
ITEM	PART No.	DESCRIPTION	QTY	SIZE	MATERIAL	NOTES

EXPLODED VIEW

200B47.5-54/64

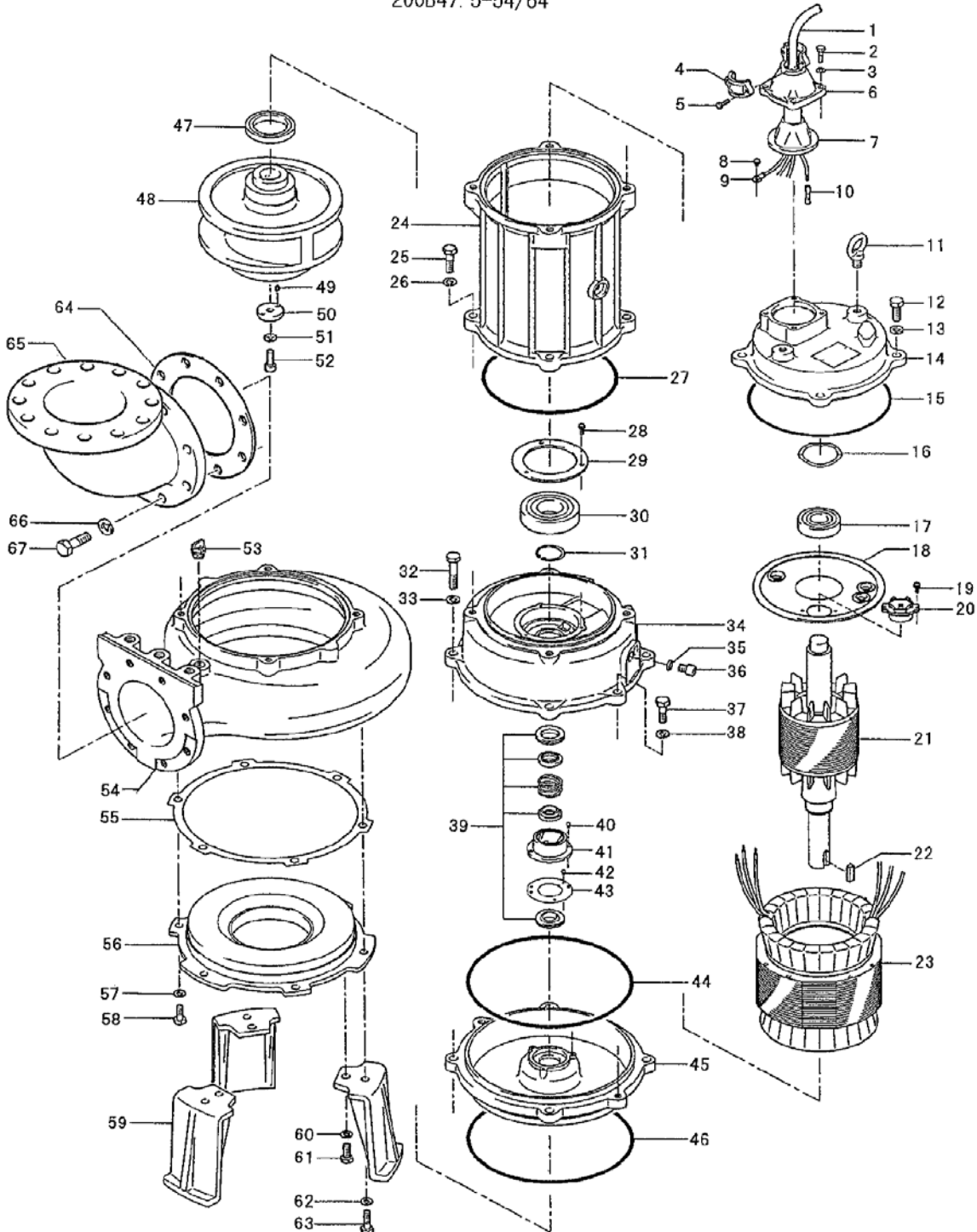

C-01239-1