

PARTS LIST		SEWAGE & WASTEWATER PUMPS			3/26/2013	
ITEM	PART No.	DESCRIPTION	QTY	SIZE	MATERIAL	NOTES
1	140-055-10	Hex.Bolt	4	M8x25	SUS304	
2	142-163-18	Spring Washer	4	M8	SUS304	
3	006-126-14	Stuffing Box	1	No.2	FC	
4	070-107-18	Cable Clamp	1		FC	
5	140-035-14	Hex.Bolt	2	M6x20	SUS304	
6	001-938-12	Cabtyre Cable Set (8m)220V-60Hz(TWN)	1	2PNCT4Cx5.5mm2	KR-2	
	001-938-12	Cabtyre Cable Set (8m)380/400/415V-50Hz	1	2PNCT4Cx5.5mm2	KR-2	
	001-938-12	Cabtyre Cable Set (8m)380/440V-60Hz	1	2PNCT4Cx5.5mm2	KR-2	
7	008-143-13	Mould Cover	1	KR2-8	CR	
8	009-276-19	Compression type Terminal	3	TMNB-5.5(Insulated)		
9	143-085-21	Pan Screw (w/Spring Washer)	1	M4x6	SWRM	
10	009-130-10	Terminal	1	R-5.5-4	CU	
11	140-098-15	Hex.Bolt	4	M12x35	SUS304	
12	142-165-10	Spring Washer	4	M12	SUS304	
13	050-000-23	Motor Bracket	1		FC	
14	072-107-14	Eye Bolt	2	M16	SS	
15	142-399-15	Washer		d17xd29x0.1t	SUS304	
	142-400-10	Washer		d17xd29x0.3t	SUS304	
16	122-173-19	O-Ring	1	V-225(222.5xd6)	NBR	
17	142-000-08	Wave Washer	1	6306B(d71xd59x4.0t)	SK5	
18	052-000-25	Bearing (w/O-ring)	1	AC-6306ZZC3		
19	058-000-09	Lead Wire Protection Plate	1	d86xd224x1.6t	SPHC	
20	143-126-12	Pan Screw (w/Spring Washer/Plain Washer)	2	M4x12	SWRM	
21	053-456-12	Motor Protector 220V-60Hz(TWN)	1	KA314-HLBL00	(H.C)	
	053-485-10	Motor Protector 380/400/415V-50Hz	1	KA314-HKXL00	(H.C)	
	053-485-10	Motor Protector 380/440V-60Hz	1	KA314-HKXL00	(H.C)	
22	055-000-82	Rotor	1Set			
23	147-005-16	Impeller Key	1	12x8x40	SUS304	
24	056C0119	Stator 220V-60Hz(TWN)	1Set			
	056C0210	Stator 380/400/415V-50Hz	1Set			
	056C0210	Stator 380/440V-60Hz	1Set			
25	064-000-12	Motor Frame	1		FC	
26	140-100-11	Hex.Bolt	4	M12x45	SUS304	
27	142-165-10	Spring Washer	4	M12	SUS304	
28	122-173-19	O-Ring	1	V-225(222.5xd6)	NBR	
29	140-000-06	Hex.Bolt (w/Spring Washer/Plain Washer)	3	M6x12	SWCH	
30	052-113-11	Bearing	1	6310ZZC3		
31	140-099-16	Hex.Bolt	2	M12x40	SUS304	
32	142-165-10	Spring Washer	2	M12	SUS304	
33	140-104-15	Hex.Bolt	4	M12x65	SUS304	
34	142-165-10	Spring Washer	4	M12	SUS304	
35	060-000-52	Bearing Housing	1		FC	
36	035-113-18	Oil Plug	2	M12x14	SUS304	
37	121-247-12	Packing	2	d12.3xd18x2t	PE	

PARTS LIST		SEWAGE & WASTEWATER PUMPS			3/26/2013	
ITEM	PART No.	DESCRIPTION	QTY	SIZE	MATERIAL	NOTES
38	025-000-38	Mechanical Seal	1	H-40	SiC	
39	143-070-23	Pan Screw	2	M5x6	SWRM	
40	030-141-10	Oil Lifter	1	H-40(T)	Resin	
41	143-070-10	Pan Screw	3	M5x6	SWRM	
42	030-149-18	Seal Stopper	1	H-40/45	SPCC	
43	122-159-19	O-Ring	1	G-280(279.3xd5.7)	NBR	
44	029-000-24	Oil Casing	1	150B47.5H-53/63	FC	
45	026-117-14	Oil Seal	1	TC-709212	NBR	
46	021-004-42	Impeller (50Hz)	1	150B47.5H-53	FC	
46	021-004-43	Impeller (60Hz)	1	150B47.5H-63	FC	
47	144-530-16	Hex. Socket Cap Screw	2	M6x15	SUS304	
48	142-202-10	Impeller Fixing Washer	1	d13xd50x15t	SUS304	
49	142-000-22	Spring Washer	1	M12(CP)	SUS304	
50	140-304-17	Hex.Socket Cap Bolt	1	M12x45	SUS304	
51	046-107-13	Air Release Valve	1	PT-1/2	Nylon	
52	122-159-19	O-Ring	1	G-280(279.3xd5.7)	NBR	
53	020-647-10	Pump Casing	1	150-7.5-4BH	FC	
54	120-102-11	Packing (S.Cover)		d301xd328x0.3t	PE	
55	022-000-73	Suction Cover	1	150B47.5H-53/63	FC	
56	023-288-18	Pump Stand	3	55/110-CE2	FC	
57	142-165-10	Spring Washer	3	M12	SUS304	
58	140-097-14	Hex.Bolt	3	M12x30	SUS304	
59	142-165-10	Spring Washer	3	M12	SUS304	
60	140-097-14	Hex.Bolt	3	M12x30	SUS304	
61	142-165-10	Spring Washer	3	M12	SUS304	
62	140-105-16	Hex.Bolt	3	M12x70	SUS304	
63	121-165-28	Packing	1	JIS5Kx150mm	NR	
64	037-119-10	Discharge Bend	1	150x150mm	FC	
65	142-166-11	Spring Washer	8	M16	SUS304	
66	140-127-14	Hex.Bolt	8	M16x55	SUS304	
		<Guide rail rail fittings>				
57	142-165-10	Spring Washer	6	M12	SUS304	
58	140-103-14	Hex.Bolt	6	M12x60	SUS304	
	093-134-15	Guide Hook	1	TOS-150	FCD	
	140-153-19	Hex.Bolt	3	M20x75	SUS304	
	142-168-13	Spring Washer	3	M20	SUS304	
	091-156-17	Duck Foot Bend(JIS10K)	1	TOS-150	FC	
	096-102-13	Guide Connector	2	51mm	FC	
	140-103-14	Hex.Bolt	2	M12x60	SUS304	
	142-165-10	Spring Washer	2	M12	SUS304	
	094-211-10	Guide Support	1	TOS-150C	SUS304	
	140-099-16	Hex.Bolt	3	M12x40	SUS304	
	141-007-10	Hex.Nut	3	M12	SUS304	
	142-129-12	Plain Washer	3	M12	SUS304	

PARTS LIST		SEWAGE & WASTEWATER PUMPS			3/26/2013	
ITEM	PART No.	DESCRIPTION	QTY	SIZE	MATERIAL	NOTES

EXPLODED VIEW

150B47.5H-53/63

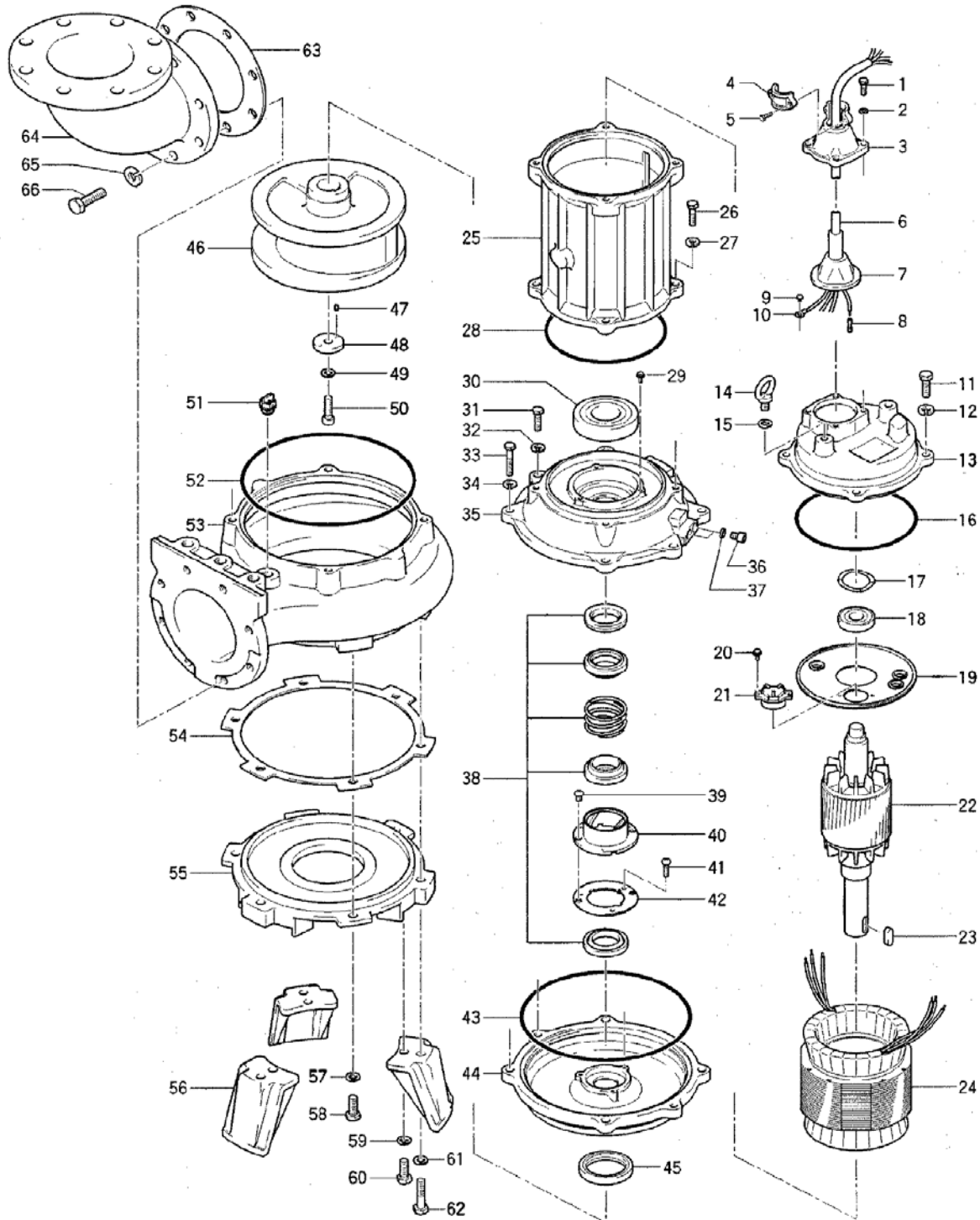

管理no. C-00744-1