

PARTS LIST		SEWAGE & WASTEWATER PUMPS			3/26/2013	
ITEM	PART No.	DESCRIPTION	QTY	SIZE	MATERIAL	NOTES
1		Cable Set				
1	001-005-20	Cable Set (10m)	1	H07RN4Gx4mm2(Gray)	KR-2(HAR)	
2	140-055-10	Hex.Bolt	4	M8x25	SUS304	
3	142-163-18	Spring Washer	4	M8	SUS304	
4	070-107-18	Cable Clamp	1		FC	
5	140-035-14	Hex.Bolt	2	M6x20	SUS304	
6	006-126-14	Stuffing Box	1	No.2	FC	
7	008-143-13	Mould Cover	1	KR2-8	CR	
8	143-085-21	Pan Screw (w/Spring Washer)	1	M4x6	SWRM	
9	009-130-10	Terminal	1	R-5.5-4	CU	
10	009-276-19	Compression type Terminal	3	TMNB-5.5(Insulated)		
11	072-107-14	Eye Bolt	2	M16	SS	
12	140-098-15	Hex.Bolt	4	M12x35	SUS304	
13	142-165-10	Spring Washer	4	M12	SUS304	
14	050-439-10	Motor Bracket	1		FC	
15	122-173-19	O-Ring	1	V-225(222.5xd6)	NBR	
16	142-198-12	Wave Washer	1	6306	SK5	
17	122-245-13	O-Ring	1	71.4xd3.1	NBR	
18	052-109-14	Bearing	1	6306ZZC3		
19	058-000-09	Lead Wire Protection Plate	1	d86xd224x1.6t	SPHC	
20	143-126-12	Pan Screw (w/Spring Washer/Plain Washer)	2	M4x12	SWRM	
21		Motor Protector				
	053-456-12	Motor Protector 220V-60Hz	1	KA314-HLBL00	(H.C)	
	053-418-25	Motor Protector 380V-50Hz	1	KA314-HKZL00	(H.C)	
	053-418-25	Motor Protector 380V-60Hz	1	KA314-HKZL00	(H.C)	
	053-491-19	Motor Protector 400/415V-50Hz	1	KA314-HKXL202	(H.C)	
	053-491-19	Motor Protector 400/440/460V-60Hz	1	KA314-HKXL202	(H.C)	
	053-491-19	Motor Protector 480V-60Hz	1	KA314-HKXL202	(H.C)	
22	055-743-15	Rotor	1Set			
23	147-067-16	Impeller Key	1	10x8x32l	SUS420	
24		Stator	1Set			
25	064-506-12	Motor Frame	1		FC	
26	140-100-11	Hex.Bolt	4	M12x45	SUS304	
27	142-165-10	Spring Washer	4	M12	SUS304	
28	122-006-10	O-Ring	1	P-8(7.8xd1.9)	NBR	
29	144-550-12	Stator Set Bolt	1	M8x12.5	SUS304	
30	122-173-19	O-Ring	1	V-225(222.5xd6)	NBR	
31	140-032-37	Hex.Bolt	3	M6x15	SWRM	
32	062-223-16	Bearing Fixing Plate	1	d92xd130x4.5t	SS	
33	052-112-10	Bearing	1	6309ZZC3		
34	146-027-11	Retaining Ring	1	C45	SK5	
35	060-430-12	Bearing Housing	1		FC	
36	121-247-12	Packing	2	d12.3xd18x2t	PE	
37	035-113-18	Oil Plug	2	M12x14	SUS304	

PARTS LIST		SEWAGE & WASTEWATER PUMPS			3/26/2013	
ITEM	PART No.	DESCRIPTION	QTY	SIZE	MATERIAL	NOTES
38	140-099-16	Hex.Bolt	2	M12x40	SUS304	
39	142-165-10	Spring Washer	2	M12	SUS304	
40	140-104-15	Hex.Bolt	4	M12x65	SUS304	
41	142-165-10	Spring Washer	4	M12	SUS304	
42	025-280-16	Mechanical Seal	1	H-35A	SIC+CCBN	
43	143-070-23	Pan Screw	2	M5x6	SWRM	
44	030-156-18	Oil Lifter	1	H-35(A)(T)	Resin	
45	143-070-10	Pan Screw	3	M5x6	SWRM	
46	030-150-12	Seal Stopper	1	H-35(A)(T)	SPCC	
47	122-159-19	O-Ring	1	G-280(279.3xd5.7)	NBR	
48	029-187-14	Oil Casing	1	100-5.5/7.5-4B2	FC	
49	122-159-19	O-Ring	1	G-280(279.3xd5.7)	NBR	
50	026-115-12	Oil Seal	1	TC-608212	NBR	
51	021B4213	Impeller (50Hz)	1	150B47.5H-51	FC	
51	021B4314	Impeller (60Hz)	1	150B47.5H-61	FC	
52	142-202-10	Impeller Fixing Washer	1	d13xd50x15t	SUS304	
53	144-293-27	Hex.Socket Set Screw	2	M6x12	SUS304	
54	140-303-16	Hex.Socket Cap Bolt	1	M12x40	SUS304	
55	037-119-10	Discharge Bend	1	150x150mm	FC	
56	121-165-28	Packing	1	JIS5Kx150mm	NR	
57	140-127-14	Hex.Bolt	8	M16x55	SUS304	
58	142-166-11	Spring Washer	8	M16	SUS304	
59	046-107-13	Air Release Valve	1	PT-1/2	Nylon	
60	020-647-10	Pump Casing	1	150-7.5-4BH	FC	
61	120-102-11	Packing (S.Cover)		d301xd328x0.3t	PE	
62	022-607-14	Suction Cover	1	150-7.5-4BH	FC	
63	142-165-10	Spring Washer	3	M12	SUS304	
64	140-097-14	Hex.Bolt	3	M12x30	SUS304	
65	023-288-18	Pump Stand	3	55/110-CE2	FC	
66	142-165-10	Spring Washer	3	M12	SUS304	
67	140-097-14	Hex.Bolt	3	M12x30	SUS304	
68	142-165-10	Spring Washer	3	M12	SUS304	
69	140-099-16	Hex.Bolt	3	M12x40	SUS304	
		<Packing O-Ring Set>				
	173-532-18	Packing O-Ring Set	1Set	(Marked by *)		
15	122-173-19	O-Ring (M.Bracket/M.Frame)	1	V-225(222.5xd6)	NBR	
17	122-245-13	O-Ring (Upp. Bearing)	1	71.4xd3.1	NBR	
28	122-006-10	O-Ring (Stator Set Bolt)	1	P-8(7.8xd1.9)	NBR	
30	122-173-19	O-Ring (M.Frame/Brg.Housing)	1	V-225(222.5xd6)	NBR	
36	121-247-12	Packing (Oil Plug)	2	d12.3xd18x2t	PE	
47	122-159-19	O-Ring (Brg.Housing/O.Casing)	1	G-280(279.3xd5.7)	NBR	
49	122-159-19	O-Ring (O.Casing/P.Casing)	1	G-280(279.3xd5.7)	NBR	
		Lubricant		Turbine Oil VG32 5,200ml		
	183-013-19	Impeller Puller		BE No.13 2"	SGPSS	

PARTS LIST		SEWAGE & WASTEWATER PUMPS			3/26/2013	
ITEM	PART No.	DESCRIPTION	QTY	SIZE	MATERIAL	NOTES

EXPLODED VIEW

150B47.5H-51/61(150-7.5-4BH2)
 150B47.5L-51/61(150-7.5-4BL2)
 200B47.5-51/61(200-7.5-4BL2)

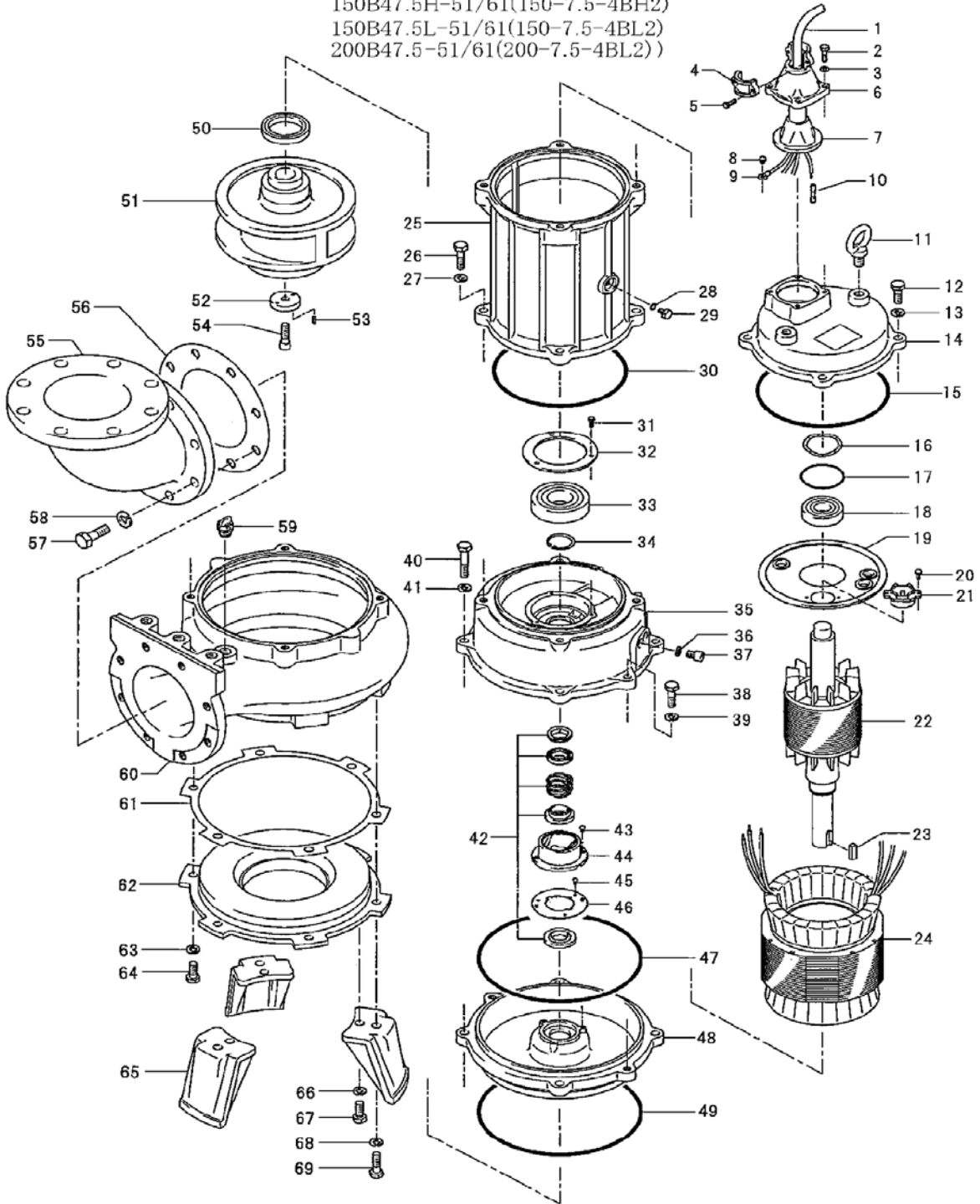

C-00251-1