

PARTS LIST		CONTRACTOR PUMPS			9/6/2013	
ITEM	PART No.	DESCRIPTION	QTY	SIZE	MATERIAL	NOTES
1		Cable Set				
1	001-005-20	Cable Set (10m)	1	H07RN4Gx4mm2(Gray)	KR-2(HAR)	
2	140-055-10	Hex.Bolt	4	M8x25	SUS304	
3	142-163-18	Spring Washer	4	M8	SUS304	
4	070-107-18	Cable Clamp	1		FC	
5	140-035-14	Hex.Bolt	2	M6x20	SUS304	
6	006-126-14	Stuffing Box	1	No.2	FC	
7	008-143-13	Mould Cover	1	KR2-8	CR	
8	143-085-21	Pan Screw (w/Spring Washer)	1	M4x6	SWRM	
9	009-130-10	Terminal	1	R-5.5-4	CU	
10	009-276-19	Compression type Terminal	3	TMNB-5.5(Insulated)		
11	072-107-14	Eye Bolt	2	M16	SS	
12	140-098-15	Hex.Bolt	4	M12x35	SUS304	
13	142-165-10	Spring Washer	4	M12	SUS304	
14	050-439-10	Motor Bracket	1		FC	
15	122-173-19	O-Ring	1	V-225(222.5xd6)	NBR	
16	142-198-12	Wave Washer	1	6306	SK5	
17	122-245-13	O-Ring	1	71.4xd3.1	NBR	
18	052-109-14	Bearing	1	6306ZZC3		
19	058-000-09	Lead Wire Protection Plate	1	d86xd224x1.6t	SPHC	
20	143-126-12	Pan Screw (w/Spring Washer/Plain Washer)	2	M4x12	SWRM	
21		Motor Protector				
21	053-456-12	Motor Protector 220V-60Hz	1	KA314-HLBL00	(H.C)	
21	053-418-25	Motor Protector 380V-50Hz	1	KA314-HKZL00	(H.C)	
21	053-418-25	Motor Protector 380V-60Hz	1	KA314-HKZL00	(H.C)	
21	053-491-19	Motor Protector 400/415V-50Hz	1	KA314-HKXL202	(H.C)	
21	053-491-19	Motor Protector 400/440/460V-60Hz	1	KA314-HKXL202	(H.C)	
21	053-491-19	Motor Protector 480V-60Hz	1	KA314-HKXL202	(H.C)	
22	055-743-15	Rotor	1Set			
23	147-067-16	Impeller Key	1	10x8x32l	SUS420	
24		Stator	1Set			
25	064-506-12	Motor Frame	1		FC	
26	140-100-11	Hex.Bolt	4	M12x45	SUS304	
27	142-165-10	Spring Washer	4	M12	SUS304	
28	122-006-10	O-Ring	1	P-8(7.8xd1.9)	NBR	
29	144-550-12	Stator Set Bolt	1	M8x12.5	SUS304	
30	122-173-19	O-Ring	1	V-225(222.5xd6)	NBR	
31	140-032-37	Hex.Bolt	3	M6x15	SWRM	
32	062-223-16	Bearing Fixing Plate	1	d92xd130x4.5t	SS	
33	052-112-10	Bearing	1	6309ZZC3		
34	146-027-11	Retaining Ring	1	C45	SK5	
35	060-430-12	Bearing Housing	1		FC	
36	121-247-12	Packing	2	d12.3xd18x2t	PE	
37	035-113-18	Oil Plug	2	M12x14	SUS304	

PARTS LIST		CONTRACTOR PUMPS			9/6/2013	
ITEM	PART No.	DESCRIPTION	QTY	SIZE	MATERIAL	NOTES
38	140-099-16	Hex.Bolt	2	M12x40	SUS304	
39	142-165-10	Spring Washer	2	M12	SUS304	
40	140-104-15	Hex.Bolt	4	M12x65	SUS304	
41	142-165-10	Spring Washer	4	M12	SUS304	
42	025-280-16	Mechanical Seal	1	H-35A	SIC+CCBN	
43	143-070-23	Pan Screw	2	M5x6	SWRM	
44	030-156-18	Oil Lifter	1	H-35(A)(T)	Resin	
45	143-070-10	Pan Screw	3	M5x6	SWRM	
46	030-150-12	Seal Stopper	1	H-35(A)(T)	SPCC	
47	122-159-19	O-Ring	1	G-280(279.3xd5.7)	NBR	
48	029-187-14	Oil Casing	1	100-5.5/7.5-4B2	FC	
49	122-159-19	O-Ring	1	G-280(279.3xd5.7)	NBR	
50	026-115-12	Oil Seal	1	TC-608212	NBR	
51	040-124-18	Impeller Shim		d25.2xd35x0.3t	SUS304	
52	021-809-15	Impeller (50Hz)	1	100C47.5-51	FC	
52	021-810-22	Impeller (60Hz)	1	100C47.5-61	FC	
53	142-202-10	Impeller Fixing Washer	1	d13xd50x15t	SUS304	
54	144-293-27	Hex.Socket Set Screw	2	M6x12	SUS304	
55	140-303-16	Hex.Socket Cap Bolt	1	M12x40	SUS304	
56	140-000-56	Hex.Bolt(For 100mm)	8	M16x75	SWRM	
56	140-130-36	Hex.Bolt(For 80mm)	8	M16x70	SWRM	
57	048-109-11	Screwed Flange(For 100mm)	1	JIS10Kx100mm(PF)	FC	
57	048-000-40	Screwed Flange(For 100mm)	1	JIS10Kx100mm(PT)	FC	
57	048-108-10	Screwed Flange(For 80mm)	1	JIS10Kx80mm(PF)	FC	
57	048-000-39	Screwed Flange(For 80mm)	1	JIS10Kx80mm(PT)	FC	
58	121-106-34	Packing(For 100mm)	1	JIS10Kx100mm	NR	
58	121-105-33	Packing(For 80mm)	1	JIS10Kx80mm	NR	
59	037-000-32	Discharge Bend(For 100mm)	1	100x100mm(S-4)	FC	
59	037-155-18	Discharge Bend(For 80mm)	1	100x80mm(S-4B)	FC	
60	142-166-37	Spring Washer	8	M16	SWRH	
61	141-008-11	Hex.Nut	8	M16	SUS304	
62	121-153-10	Packing	1	160mm2(P.C.165)	NBR	
63	140-124-11	Hex.Bolt	4	M16x40	SUS304	
64	142-166-11	Spring Washer	4	M16	SUS304	
65	046-107-13	Air Release Valve	1	PT-1/2	Nylon	
66	020-531-23	Pump Casing	1	100-5.5/7.5-4B2	FC	
67	120-102-11	Packing (S.Cover)		d301xd328x0.3t	PE	
68	022-330-26	Suction Cover	1	55/110-CE2	FCD	
69	142-165-10	Spring Washer	3	M12	SUS304	
70	140-097-14	Hex.Bolt	3	M12x30	SUS304	
71	023-288-18	Pump Stand	3	55/110-CE2	FC	
72	142-165-10	Spring Washer	3	M12	SUS304	
73	140-097-14	Hex.Bolt	3	M12x30	SUS304	
74	142-165-10	Spring Washer	3	M12	SUS304	



PARTS LIST		CONTRACTOR PUMPS				9/6/2013
ITEM	PART No.	DESCRIPTION	QTY	SIZE	MATERIAL	NOTES

## EXPLODED VIEW

100C45.5-51/61(55-CE4)  
100C47.5-51/61(75-CE4)

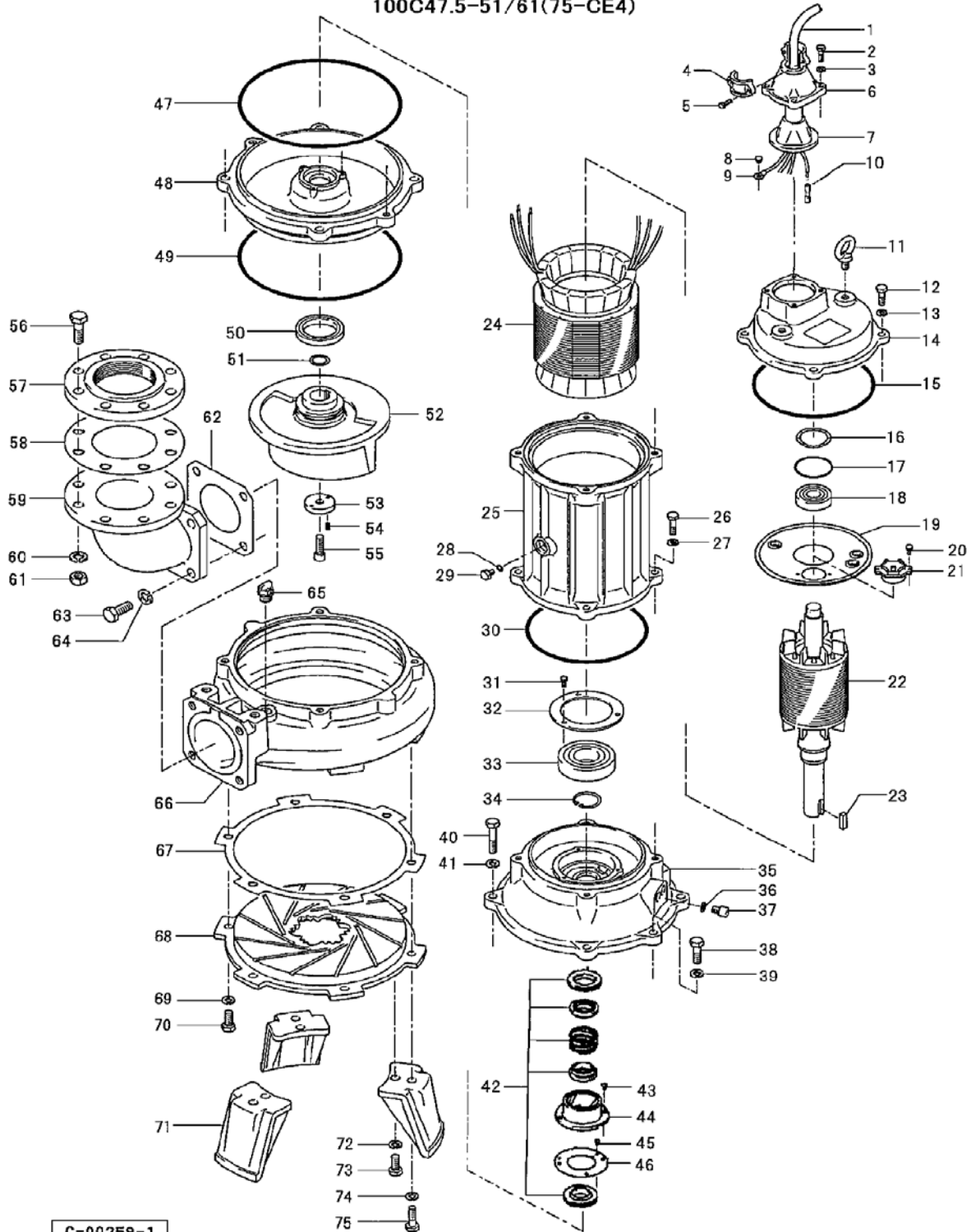

C-00259-1