

PARTS LIST		CONTRACTOR PUMPS			9/6/2013	
ITEM	PART No.	DESCRIPTION	QTY	SIZE	MATERIAL	NOTES
1	009-115-19	Connector	1	PC-4020F		
2	009-114-18	Connector	1	PC-4020M		
3	140-018-11	Hex.Bolt	3	M5x15	SUS304	
4	142-422-18	Seal Washer	3	PM-5	SUS+NBR	
5		Cabtyre Cable Set				
6	003-111-20	Gland	1		SUS304	
7	009-114-18	Connector	2	PC-4020M		
8	009-115-19	Connector	2	PC-4020F		
9	002-128-14	Heat Shrink Tube (Sold per meter)	m	EVA(d10x1t)	(V/m)	
10	009-131-11	Terminal	7	R-5.5-6	CU	
11	140-055-10	Hex.Bolt	8	M8x25	SUS304	
12	142-163-18	Spring Washer	8	M8	SUS304	
13	070-107-18	Cable Clamp	2		FC	
14	140-035-14	Hex.Bolt	4	M6x20	SUS304	
15	006-126-14	Stuffing Box	2	No.2	FC	
16		Cabtyre Cable Set				
17	008-154-17	Mould Cover	1	KR2-10	CR	
18	009-275-18	Compression type Terminal	6	TGNB-5.5(Insulated)	CU	
19		Cabtyre Cable Set				
20	008-142-12	Mould Cover	1	KR2-7	CR	
21	143-085-21	Pan Screw (w/Spring Washer)	1	M4x6	SWRM	
22	009-122-19	Terminal	1	R-3.5-4	CU	
23	140-098-15	Hex.Bolt	4	M12x35	SUS304	
24	142-165-10	Spring Washer	4	M12	SUS304	
25	050-437-18	Motor Bracket	1		FC	
26	072-107-14	Eve Bolt	2	M16	SS	
27	122-173-19	O-Ring	1	V-225(222.5xd6)	NBR	
28	142-198-12	Wave Washer	1	6306	SK5	
29	122-245-13	O-Ring	1	71.4xd3.1	NBR	
30	052-109-14	Bearing	1	6306ZZC3		
31	058-000-09	Lead Wire Protection Plate	1	d86xd224x1.6t	SPHC	
32	055-746-18	Rotor	1Set			
33	147-005-16	Impeller Key	1	12x8x40	SUS304	
34		Motor Protector				
34	053-310-13	Motor Protector	3	9700K-76-215	(H)	
35		Stator	1Set			
36	064-506-12	Motor Frame	1		FC	
37	140-100-11	Hex.Bolt	4	M12x45	SUS304	
38	142-165-10	Spring Washer	4	M12	SUS304	
39	122-006-10	O-Ring	1	P-8(7.8xd1.9)	NBR	
40	144-550-12	Stator Set Bolt	1	M8x12.5	SUS304	
41	122-173-19	O-Ring	1	V-225(222.5xd6)	NBR	
42	140-032-37	Hex.Bolt	3	M6x15	SWRM	
43	062-224-17	Bearing Fixing Plate	1	d98xd140x4.5t	SS	

PARTS LIST		CONTRACTOR PUMPS			9/6/2013	
ITEM	PART No.	DESCRIPTION	QTY	SIZE	MATERIAL	NOTES
44	052-141-18	Bearing	1Set	6310ZZD2C3		
45	142-393-19	Bearing Washer	1	AW10	SUS	
46	141-129-19	Bearing Nut	1	AN10	SUS410	
47	060-431-13	Bearing Housing	1		FC	
48	121-247-12	Packing	2	d12.3xd18x2t	PE	
49	035-113-18	Oil Plug	2	M12x14	SUS304	
50	140-099-16	Hex.Bolt	2	M12x40	SUS304	
51	142-165-10	Spring Washer	2	M12	SUS304	
52	140-104-15	Hex.Bolt	4	M12x65	SUS304	
53	142-165-10	Spring Washer	4	M12	SUS304	
54	025-000-38	Mechanical Seal	1	H-40	SiC	
55	143-070-23	Pan Screw	2	M5x6	SWRM	
56	030-141-10	Oil Lifter	1	H-40(T)	Resin	
57	143-070-10	Pan Screw	3	M5x6	SWRM	
58	030-149-18	Seal Stopper	1	H-40/45	SPCC	
59	122-159-19	O-Ring	1	G-280(279.3xd5.7)	NBR	
60	029-191-11	Oil Casing	1	110-CE2	FC	
61	122-159-19	O-Ring	1	G-280(279.3xd5.7)	NBR	
62	026-117-14	Oil Seal	1	TC-709212	NBR	
63	040-124-18	Impeller Shim		d25.2xd35x0.3t	SUS304	
64	021-839-14	Impeller (50Hz)	1	100C411-51	FC	
64	021-840-18	Impeller (60Hz)	1	100C411-61	FC	
65	142-202-10	Impeller Fixing Washer	1	d13xd50x15t	SUS304	
66	144-293-27	Hex.Socket Set Screw	2	M6x12	SUS304	
67	140-303-16	Hex.Socket Cap Bolt	1	M12x40	SUS304	
68	046-107-13	Air Release Valve	1	PT-1/2	Nylon	
69	140-000-56	Hex.Bolt(For 100mm)	8	M16x75	SWRM	
69	140-130-36	Hex.Bolt(For 80mm)	8	M16x70	SWRM	
70	048-109-11	Screwed Flange(For 100mm)	1	JIS10Kx100mm(PF)	FC	
70	048-000-40	Screwed Flange(For 100mm)	1	JIS10Kx100mm(PT)	FC	
70	048-108-10	Screwed Flange(For 80mm)	1	JIS10Kx80mm(PF)	FC	
70	048-000-39	Screwed Flange(For 80mm)	1	JIS10Kx80mm(PT)	FC	
71	121-106-34	Packing(For 100mm)	1	JIS10Kx100mm	NR	
71	121-105-33	Packing(For 80mm)	1	JIS10Kx80mm	NR	
72	037-000-32	Discharge Bend(For 100mm)	1	100x100mm(S-4)	FC	
72	037-155-18	Discharge Bend(For 80mm)	1	100x80mm(S-4B)	FC	
73	142-166-37	Spring Washer	8	M16	SWRH	
74	141-008-11	Hex.Nut	8	M16	SUS304	
75	121-153-10	Packing	1	160mm2(P.C.165)	NBR	
76	140-124-11	Hex.Bolt	4	M16x40	SUS304	
77	142-166-11	Spring Washer	4	M16	SUS304	
78	020-539-18	Pump Casing	1	110-USH/USL	FC	
79	120-102-11	Packing (S.Cover)		d301xd328x0.3t	PE	
80	022-330-26	Suction Cover	1	55/110-CE2	FCD	

PARTS LIST		CONTRACTOR PUMPS				9/6/2013
ITEM	PART No.	DESCRIPTION	QTY	SIZE	MATERIAL	NOTES

EXPLODED VIEW

100C411-51/61(110-CE4)

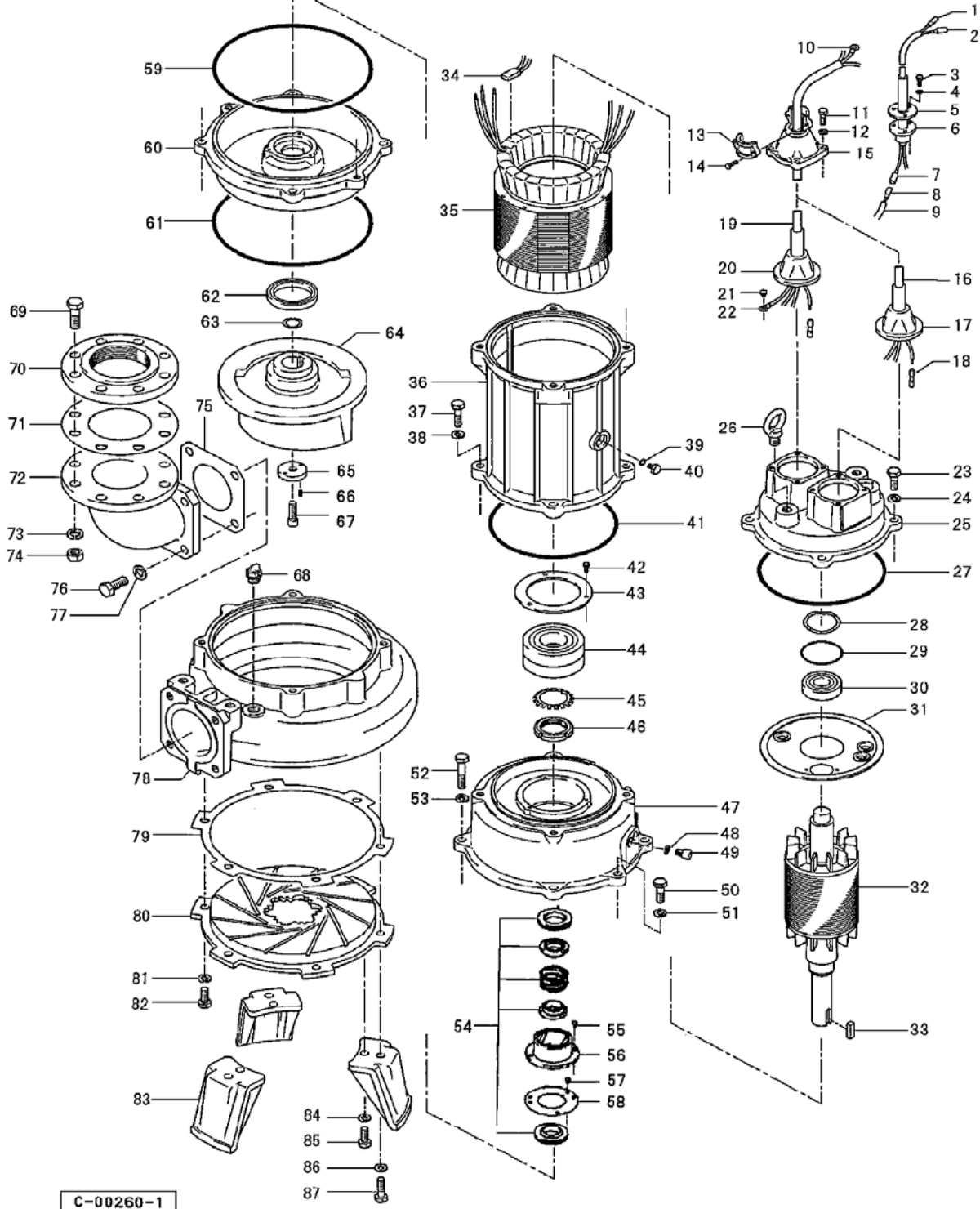

C-00260-1