



BZ-SERIES
SEWAGE & WASTEWATER PUMPS

DIMENSIONS

100BZ45.5 -64
100BZ47.5 -64

Bend model:
BEND100-100 ANSI

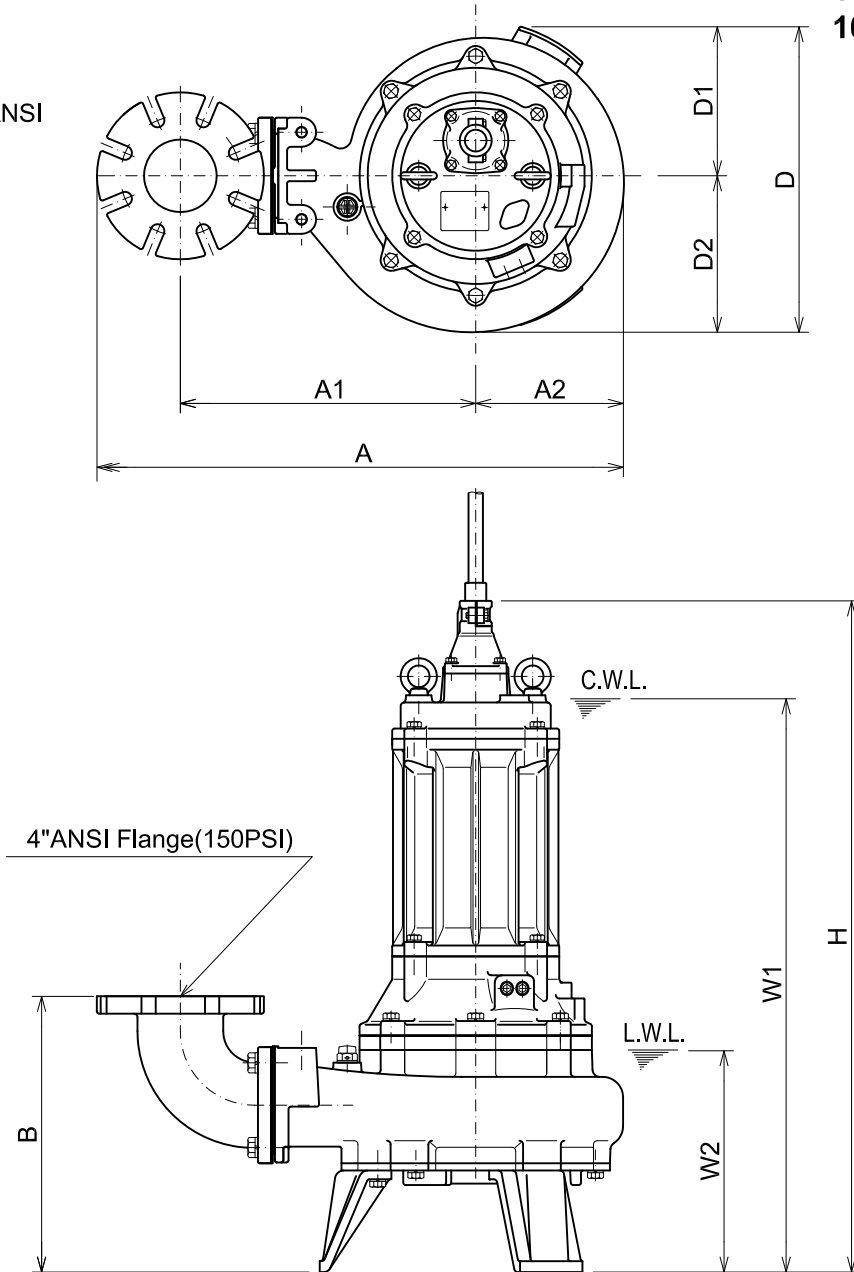

C.W.L. :Continuous running Water Level
L.W.L. :Lowest running Water Level

DIMENSIONS:USCS(Inch)

Model	HP	NOM. SIZE	Pump & Motor								C.W.L. W1	L.W.L. W2	*Wt. (lbs.)
			A	A1	A2	B	D	D1	D2	H			
100BZ45.5 -64	7.5	4"	29	16 7/16	8 1/16	14 15/16	16 9/16	8 1/16	8 1/2	36 3/8	31 1/8	12	375
100BZ47.5 -64	10	4"	29	16 7/16	8 1/16	14 15/16	16 9/16	8 1/16	8 1/2	37 3/16	32 1/4	12	417

DIMENSIONS:METRIC(mm)

Model	kW	NOM. SIZE	Pump & Motor								C.W.L. W1	L.W.L. W2	*Wt. (kg)
			A	A1	A2	B	D	D1	D2	H			
100BZ45.5 -64	5.5	100	736	417	204	380	421	205	216	924	790	305	170
100BZ47.5 -64	7.5	100	736	417	204	380	421	205	216	945	820	305	189

*Excluding Cable.