



BZ-SERIES
SEWAGE & WASTEWATER PUMPS

DIMENSIONS

Bend model:
BEND80-100 ANSI

100BZ41.5 -62
100BZ42.2 -62

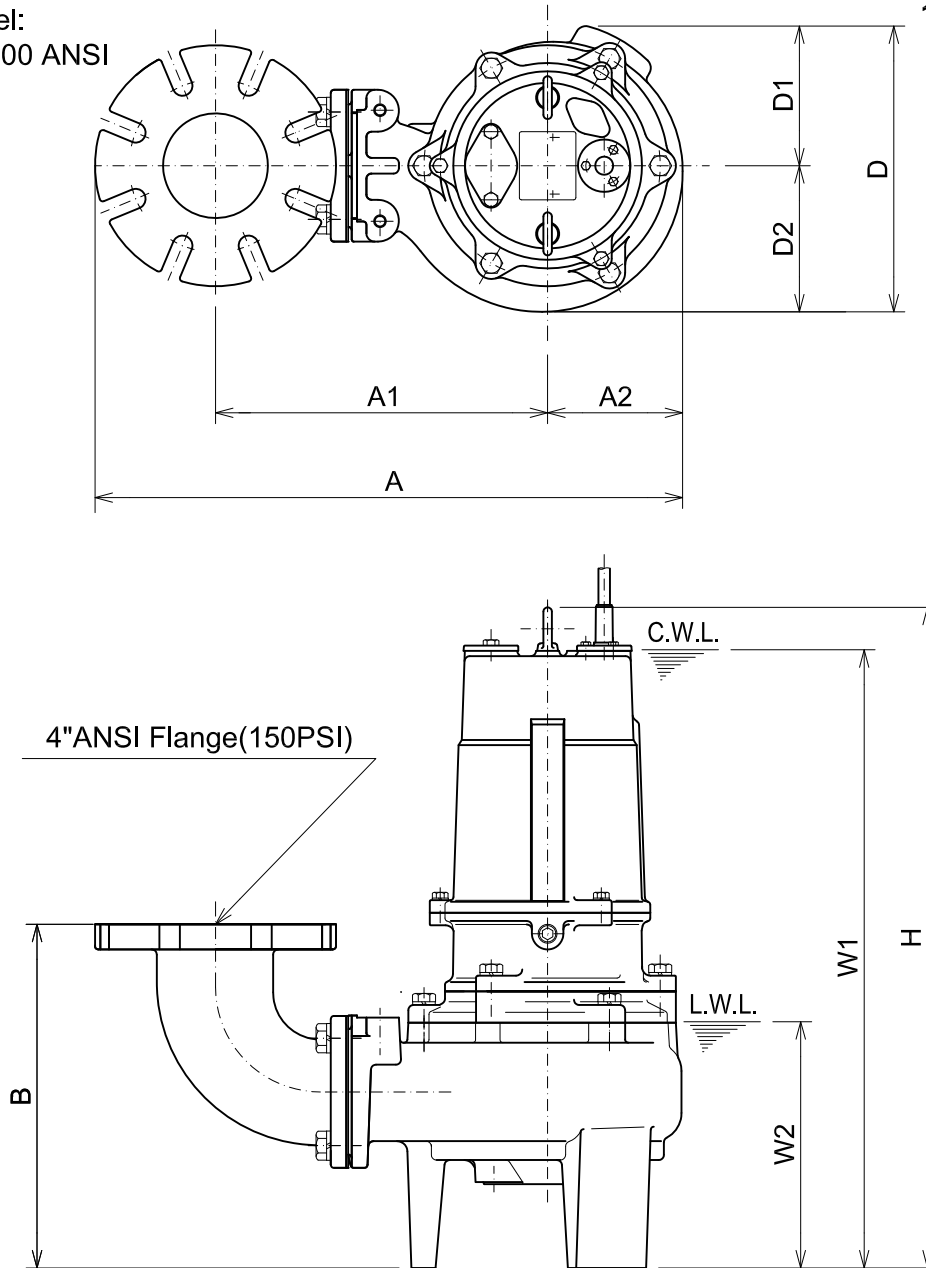

C.W.L. :Continuous running Water Level
L.W.L. :Lowest running Water Level

DIMENSIONS:USCS(Inch)

Model	HP	NOM. SIZE	Pump & Motor								C.W.L. W1	L.W.L. W2	*Wt. (lbs.)
			A	A1	A2	B	D	D1	D2	H			
100BZ41.5 -61	2	4"	22 1/2	12 7/8	5 1/16	12 15/16	10 3/4	5 1/4	5 1/2	24 13/16	23 1/4	9 1/4	170
100BZ42.2 -61	3	4"	22 1/2	12 7/8	5 1/16	12 15/16	10 3/4	5 1/4	5 1/2	24 13/16	23 1/4	9 1/4	170

DIMENSIONS:METRIC(mm)

Model	kW	NOM. SIZE	Pump & Motor								C.W.L. W1	L.W.L. W2	*Wt. (kg)
			A	A1	A2	B	D	D1	D2	H			
100BZ41.5 -61	1.5	100	571	327	129	328	273	133	140	631	590	235	77
100BZ42.2 -61	2.2	100	571	327	129	328	273	133	140	631	590	235	77

*Excluding Cable.