

TOS80C22.2-CR -61
TOS80C23.7-CR -61

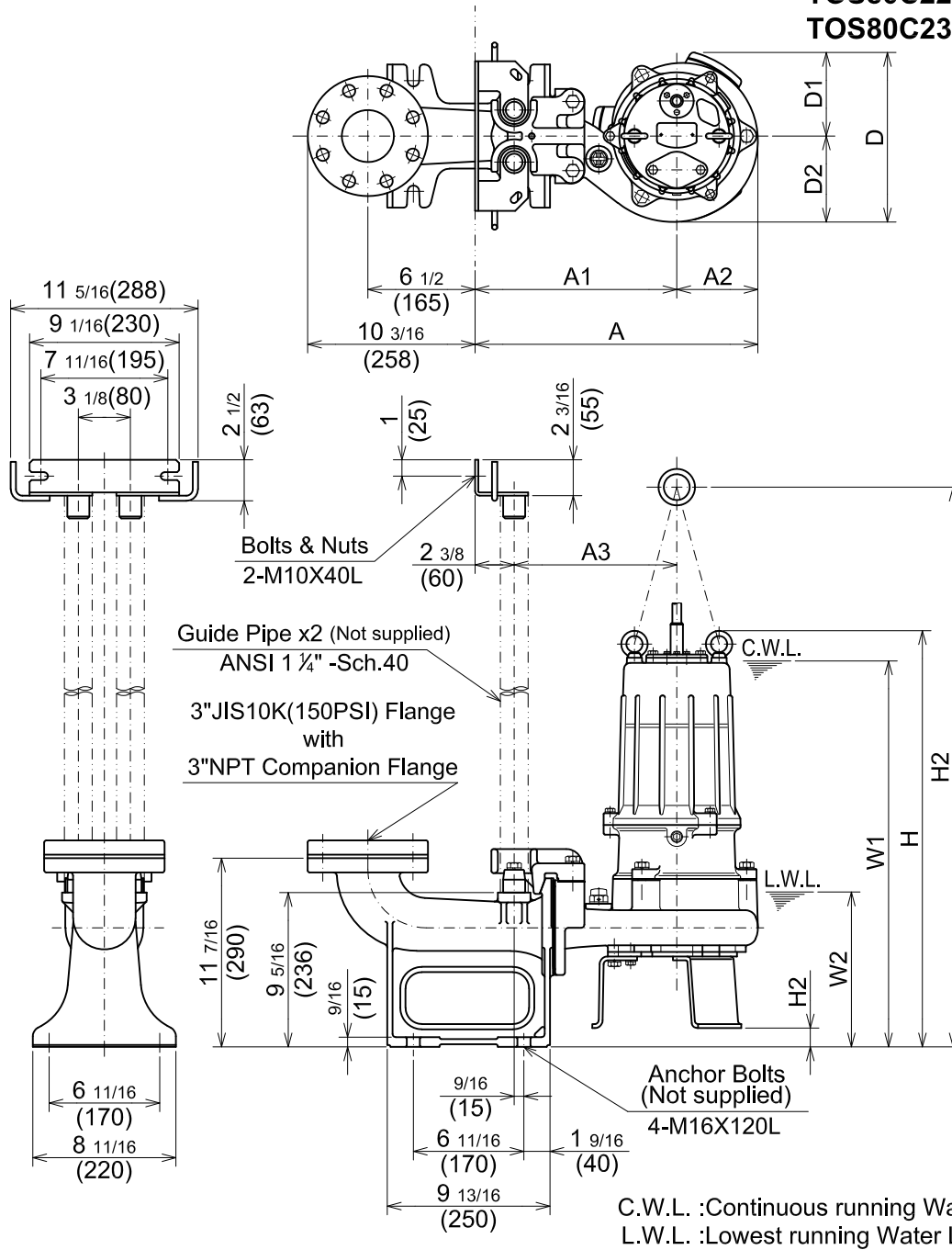

DIMENSIONS:USCS(Inch)

Model	HP	NOM. SIZE	Pump & Motor										C.W.L.	L.W.L.	Wt. (lbs.)
			A	A1	A2	A3	D	D1	D2	H	H1	H2			
TOS80C22.2-CR -61	3	3"	17 1/8	12 3/16	4 15/16	9 13/16	10 1/4	5 1/16	5 3/16	25 3/16	33 7/8	1 1/8	23 3/8	9 1/2	141
TOS80C23.7-CR -61	5	3"	17 1/8	12 3/16	4 15/16	9 13/16	10 1/4	5 1/16	5 3/16	25 3/16	33 7/8	1 1/8	23 3/8	9 1/2	141

DIMENSIONS:METRIC(mm)

Model	kW	NOM. SIZE	Pump & Motor										C.W.L.	L.W.L.	Wt. (kg)
			A	A1	A2	A3	D	D1	D2	H	H1	H2			
TOS80C22.2-CR -61	2.2	80	435	310	125	250	260	128	132	640	860	29	595	240	64
TOS80C23.7-CR -61	3.7	80	435	310	125	250	260	128	132	640	860	29	595	240	64