

TO200BZ622 -61
TO200BZ437 -61
TO200BZ445 -61

Guide rail
Model: TO-200
Weight: 198 lbs. (90kg)

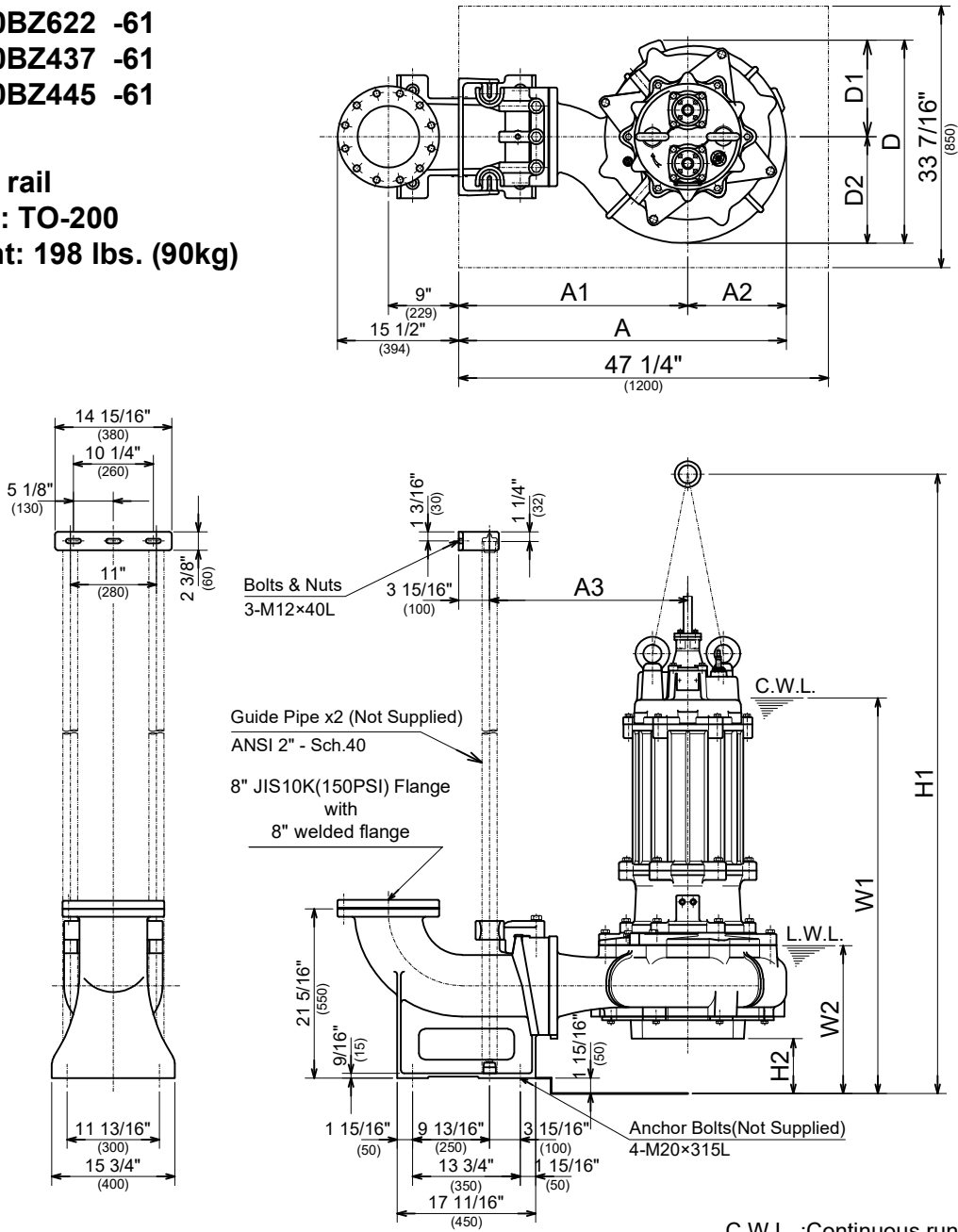

C.W.L. :Continuous running Water Level
L.W.L. :Lowest running Water Level

DIMENSIONS:USCS (Inch)

Model	HP	NOM. SIZE	Pump & Motor										C.W.L.	L.W.L.	*Wt. (lbs.)
			A	A1	A2	A3	D	D1	D2	H	H1	H2			
TO200BZ622 -61	30	8"	41 15/16	29 5/16	12 5/8	25 3/8	26	12 3/8	13 5/8	58 13/16	79 3/16	7	50 5/8	18 7/8	1570
TO200BZ437 -61	50	8"	41 15/16	29 5/16	12 5/8	25 3/8	26	12 3/8	13 5/8	58 3/8	78 3/4	7	50 1/4	18 7/8	1720
TO200BZ445 -61	60	8"	41 15/16	29 5/16	12 5/8	25 3/8	26	12 3/8	13 5/8	58 13/16	79 3/16	7	50 5/8	18 7/8	1740

DIMENSIONS:METRIC (mm)

Model	kW	NOM. SIZE	Pump & Motor										C.W.L.	L.W.L.	*Wt. (kg)
			A	A1	A2	A3	D	D1	D2	H	H1	H2			
TO200BZ622 -61	22	200	1065	744	321	644	660	314	346	1494	2012	178	1285	480	710
TO200BZ437 -61	37	200	1065	744	321	644	660	314	346	1482	2000	178	1275	480	780
TO200BZ445 -61	45	200	1065	744	321	644	660	314	346	1494	2012	178	1285	480	790

*Excluding TOS & Cable