

TO100SFQ211 -63

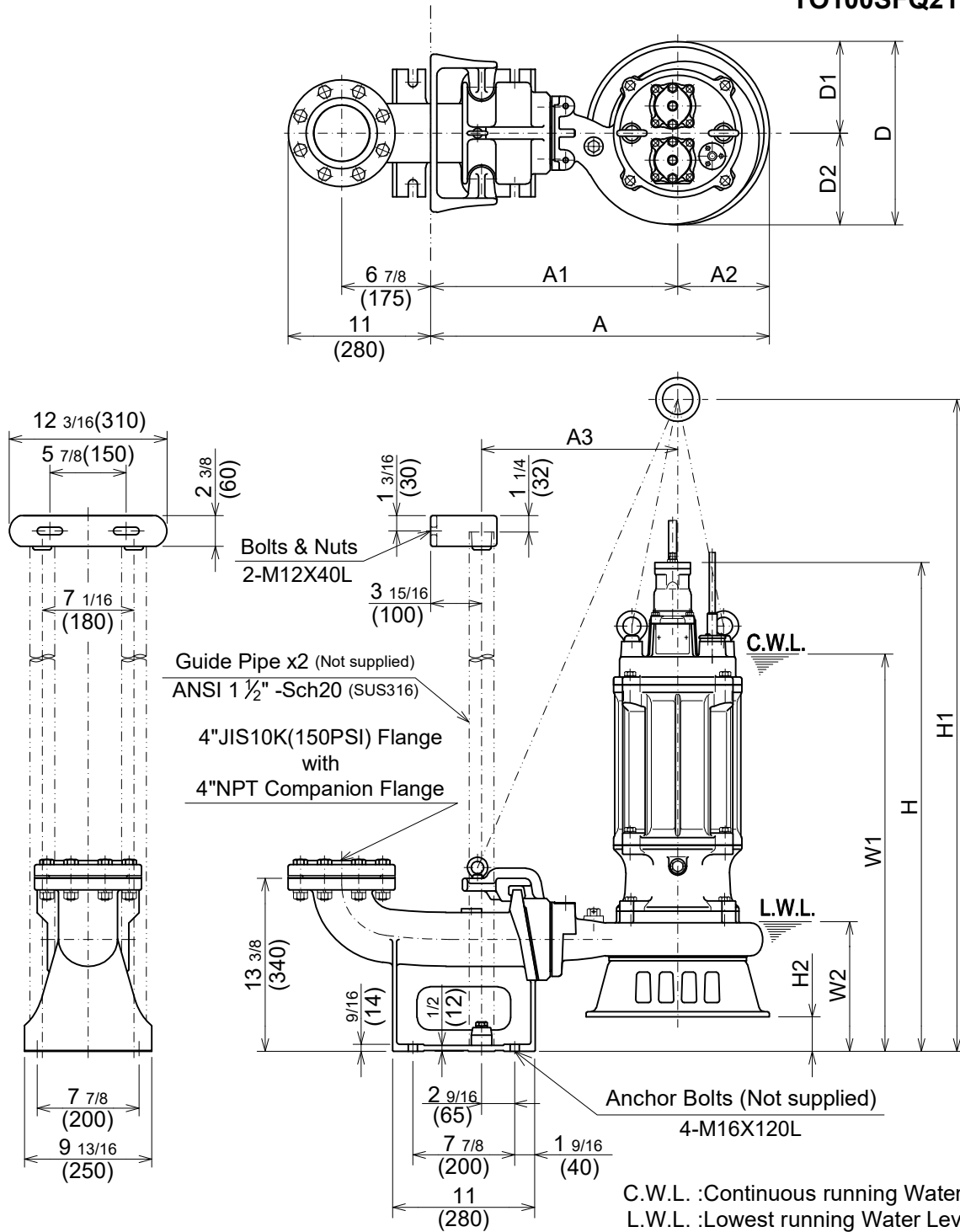

C.W.L. :Continuous running Water Level
L.W.L. :Lowest running Water Level

DIMENSIONS:USCS (Inch)

Model	HP	NOM. SIZE	Pump & Motor									C.W.L.	L.W.L.	*Wt. (lbs.)		
			A	A1	A2	A3	D	D1	D2	H	H1				H2	W1
TO100SFQ211-63	15	4"	26 3/16	19 1/8	7 1/16	15 3/16	14 3/16	7 1/16	7 1/16	7 1/16	37 13/16	50 11/16	2 11/16	30 3/4	10	317

DIMENSIONS:METRIC (mm)

Model	kW	NOM. SIZE	Pump & Motor									C.W.L.	L.W.L.	*Wt. (kg)	
			A	A1	A2	A3	D	D1	D2	H	H1				H2
TO100SFQ211-63	11	100	665	485	180	385	360	180	180	960	1287	68	780	255	144

*Excluding TO & Cable