

LH837-14-60

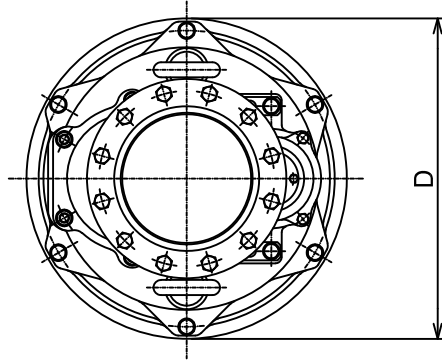

8" JIS10K(150PSI) Flange
with
8" NPT Companion Flange

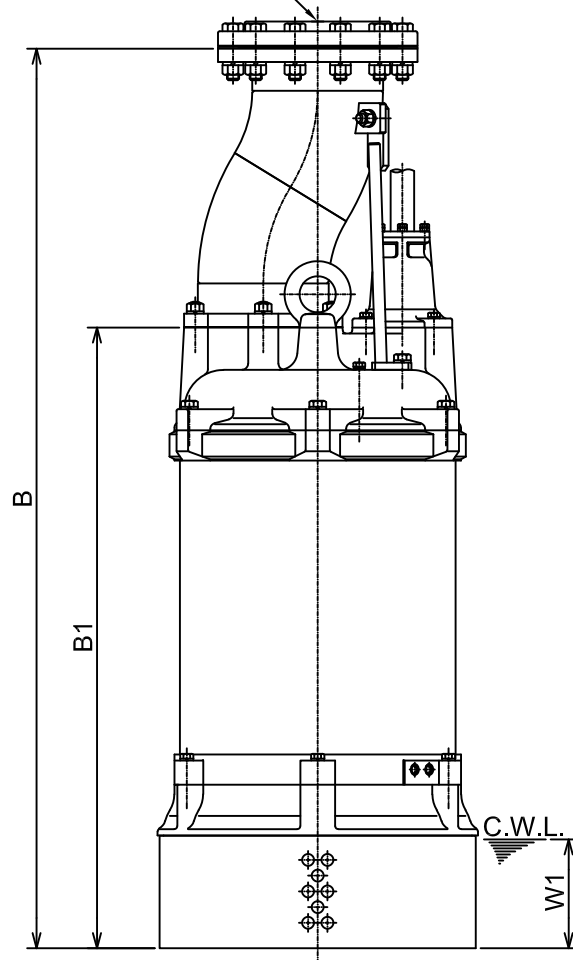

C.W.L. :Continuous running Water Level

DIMENSIONS:USCS (Inch)

Model	HP	NOM. SIZE	Pump & Motor			C.W.L.	*Wt. (lbs.)
			B	B1	D	W1	
LH837-14-60	50	8"	57	40 7/16	20 7/8	7 1/8	1190

DIMENSIONS:METRIC (mm)

Model	kW	NOM. SIZE	Pump & Motor			C.W.L.	*Wt. (kg)
			B	B1	D	W1	
LH837-14-60	37	200	1448	1027	530	180	540

*Excluding Cable