

LH12185D -61

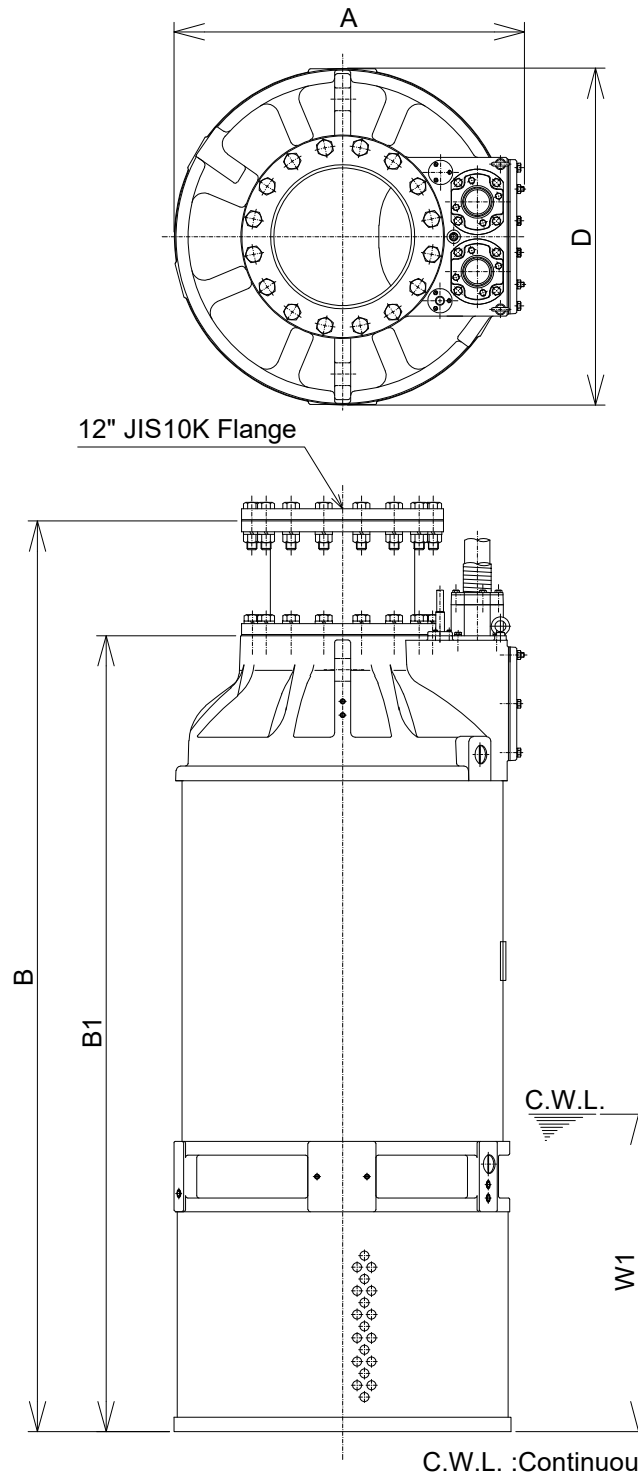

C.W.L. :Continuous running Water Level

DIMENSIONS:USCS (Inch)

Model	HP	NOM. SIZE	Pump & Motor				C.W.L. W1	*Wt. (lbs.)
			A	B	B1	D		
LH12185D -61	250	12"	30 7/16	79 1/16	69 1/8	29 1/4	27 1/2	4300

DIMENSIONS:METRIC (mm)

*Excluding Cable

Model	kW	NOM. SIZE	Pump & Motor				C.W.L. W1	*Wt. (kg)
			A	B	B1	D		
LH12185D -61	185	300	773	2008	1755	743	700	1950