

LH10110D -61

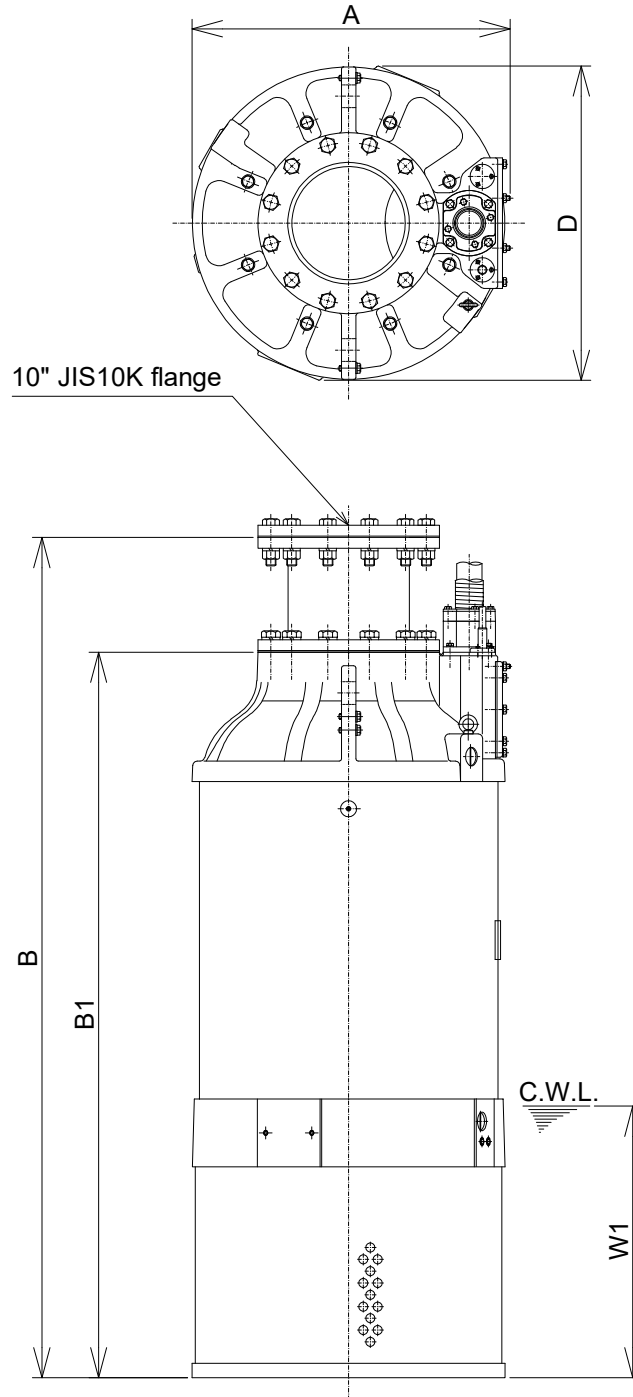

C.W.L. :Continuous running Water Level

DIMENSIONS:USCS (Inch)

Model	HP	NOM. SIZE	Pump & Motor				C.W.L.	*Wt.
			A	B	B1	D	W1	(lbs.)
LH10110D-61	150	10"	27 5/8	72 15/16	63	27 5/16	23 5/8	3190

DIMENSIONS:METRIC (mm)

*Excluding Cable

Model	kW	NOM. SIZE	Pump & Motor				C.W.L.	*Wt.
			A	B	B1	D	W1	(kg)
LH10110D-61	110	250	701	1853	1600	693	600	1450