

KTZE21.5-61
KTZE31.5-61
KTZE22.2-61
KTZE32.2-61

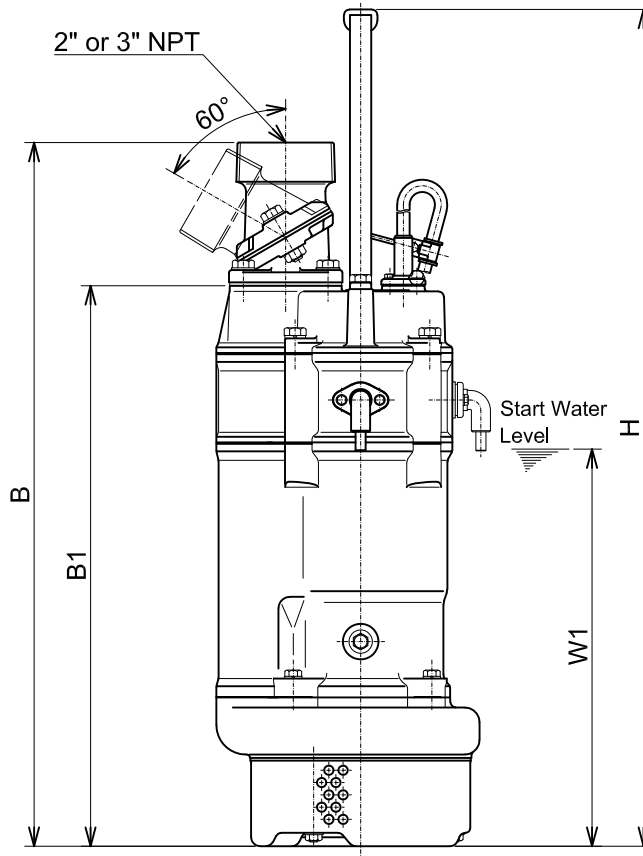

DIMENSIONS:USCS (Inch)

Model	HP	NOM. SIZE	Pump & Motor							Start	*Wt. (lbs.)
			A	As	A1	B	B1	D	H	W1	
KTZE21.5-61	2	2"	9 1/4	10 1/4	6 13/16	24	18 15/16	8 1/2	28 11/16	13 5/8	88
KTZE31.5-61	2	3"	9 1/4	10 9/16	6 13/16	24	18 15/16	8 1/2	28 11/16	13 5/8	86
KTZE22.2-61	3	2"	9 1/4	10 1/4	6 13/16	24 3/4	19 3/4	8 1/2	29 7/16	14	93
KTZE32.2-61	3	3"	9 1/4	10 9/16	6 13/16	24 3/4	19 3/4	8 1/2	29 7/16	14	90

DIMENSIONS:METRIC (mm)

*Excluding Cable

Model	kW	NOM. SIZE	Pump & Motor							Start	*Wt. (kg)
			A	As	A1	B	B1	D	H	W1	
KTZE21.5-61	1.5	50	235	261	173	609	481	216	728	345	40
KTZE31.5-61	1.5	80	235	268	173	609	481	216	728	345	39
KTZE22.2-61	2.2	50	235	261	173	629	501	216	748	355	42
KTZE32.2-61	2.2	80	235	268	173	629	501	216	748	355	41