

**KTZ47.5-63  
KTZ67.5-63**

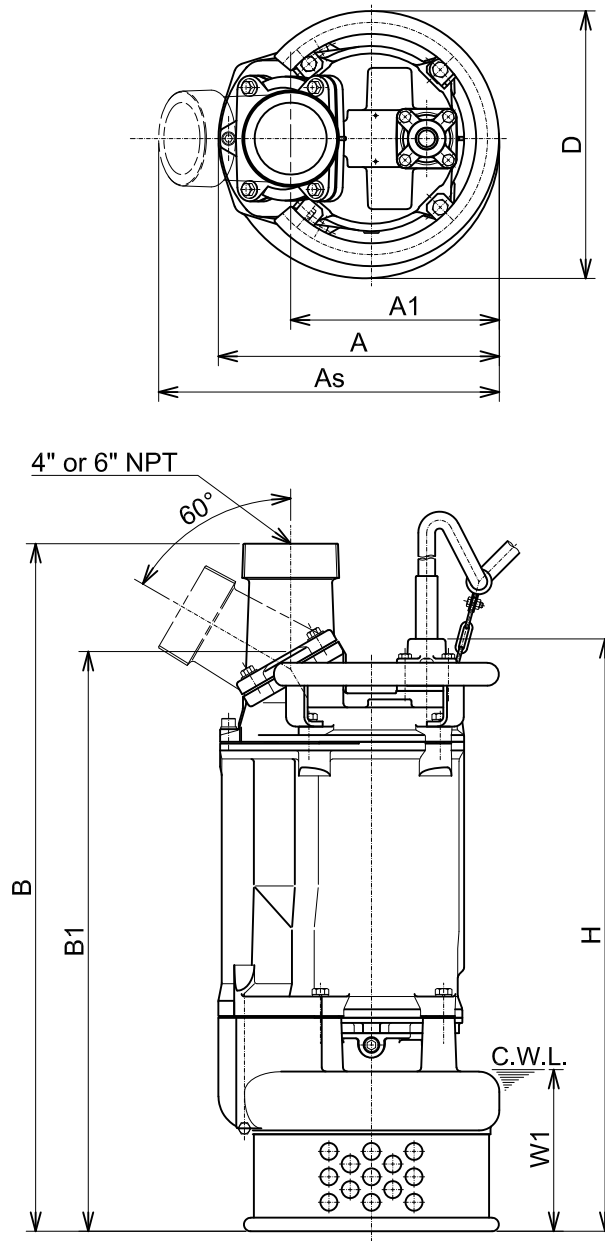

**DIMENSIONS:USCS (Inch)**

C.W.L. : Continuous running Water Level

Model	HP	NOM. SIZE	Pump & Motor							C.W.L. W1	Wt. (lbs.)
			A	As	A1	B	B1	D	H		
KTZ47.5-63	10	4"	13	15 13/16	9 5/8	31 7/8	26	12 3/8	27 7/16	7 1/2	229
KTZ67.5-63(4")	10	4"	13	15 13/16	9 5/8	31 7/8	26	12 3/8	27 7/16	7 1/2	222
KTZ67.5-63	10	*6"	14 7/16	15 1/2	11 1/4	31 7/8	26	12 3/8	27 7/16	7 1/2	227

**DIMENSIONS:METRIC (mm)** \*6" / 150mm is optional

\*Excluding Cable

Model	kW	NOM. SIZE	Pump & Motor							C.W.L. W1	Wt. (kg)
			A	As	A1	B	B1	D	H		
KTZ47.5-63	7.5	100	330	401	245	809	661	314	697	190	104
KTZ67.5-63(4")	7.5	100	330	401	245	809	661	314	697	190	101
KTZ67.5-63	7.5	*150	367	394	285	810	661	314	697	190	103