

**KTZ35.5-63
KTZ45.5-63**

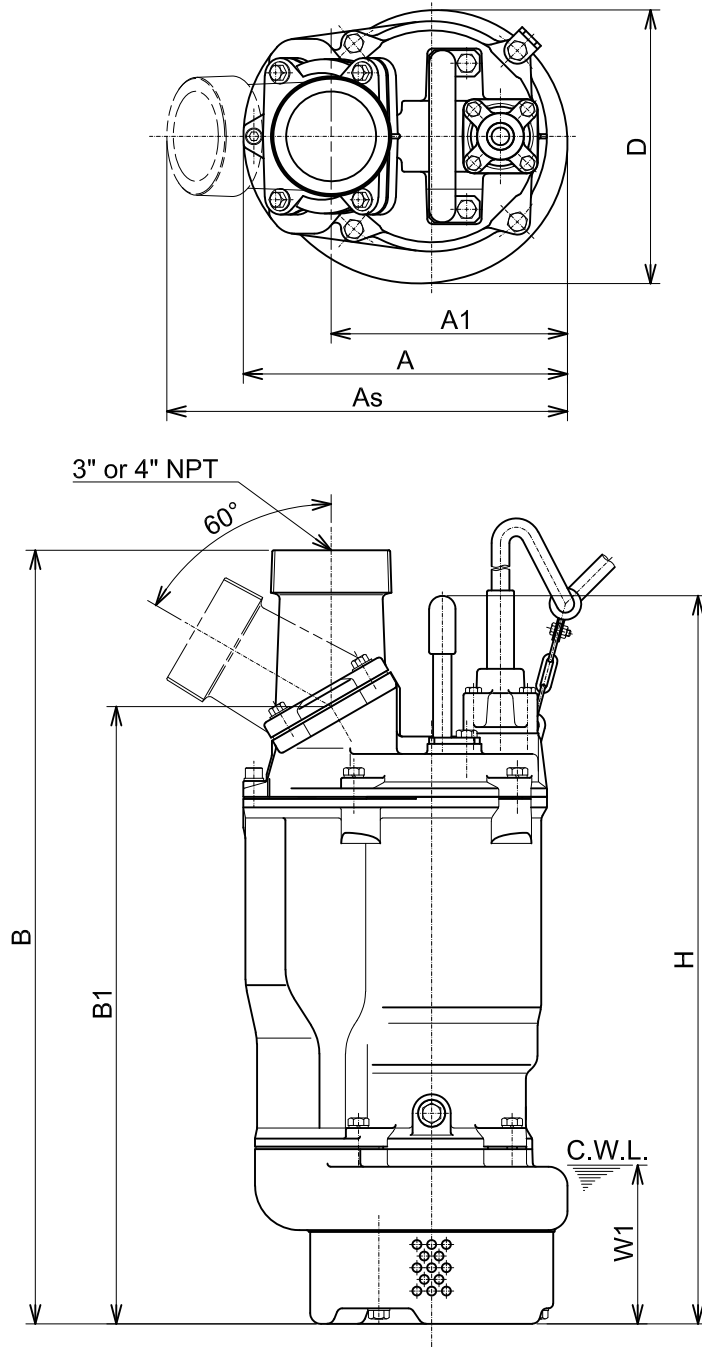

C.W.L. : Continuous running Water Level

DIMENSIONS:USCS (Inch)

Model	HP	NOM. SIZE	Pump & Motor							C.W.L.	*Wt.
			A	As	A1	B	B1	D	H	W1	(lbs.)
KTZ35.5-63	7.5	3"	12 1/16	14 5/16	8 3/4	28 3/8	22 15/16	10 3/16	27 1/16	5 7/8	167
KTZ45.5-63	7.5	4"	12 1/16	14 15/16	8 3/4	28 3/4	22 15/16	10 3/16	27 1/16	5 7/8	170

DIMENSIONS:METRIC (mm)

*Excluding Cable

Model	kW	NOM. SIZE	Pump & Motor							C.W.L.	*Wt.
			A	As	A1	B	B1	D	H	W1	(kg)
KTZ35.5-63	5.5	80	306	363	223	721	583	258	688	150	76
KTZ45.5-63	5.5	100	306	379	223	731	583	258	688	150	77