

**KTZ23.7-63
KTZ33.7-63
KTZ43.7-63**

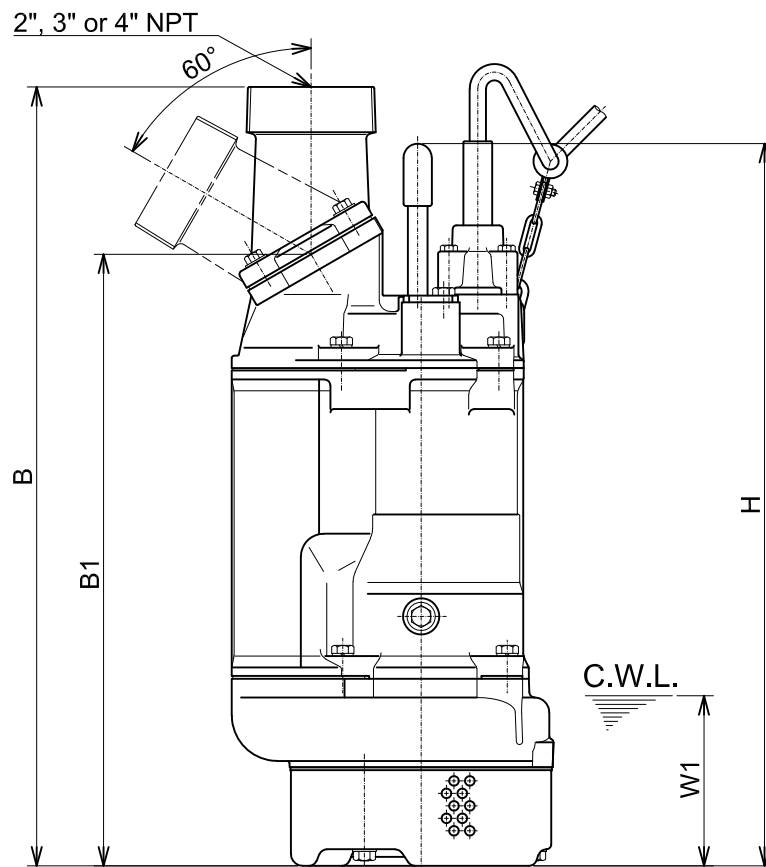

DIMENSIONS:USCS (Inch)

C.W.L. : Continuous running Water Level

Model	HP	NOM. SIZE	Pump & Motor							C.W.L. W1	*Wt. (lbs.)
			A	As	A1	B	B1	D	H		
KTZ23.7-63	5	2"	11 1/8	13 5/16	8 3/8	26 1/4	21 1/4	9 15/16	25 1/16	5 7/8	137
KTZ33.7-63	5	3"	11 1/8	13 7/8	8 3/8	26 5/8	21 1/4	9 15/16	25 1/16	5 7/8	137
KTZ43.7-63	5	4"	11 1/8	14 1/2	8 3/8	27 1/16	21 1/4	9 15/16	25 1/16	5 7/8	137

DIMENSIONS:METRIC (mm)

*Excluding Cable

Model	kW	NOM. SIZE	Pump & Motor							C.W.L. W1	*Wt. (kg)
			A	As	A1	B	B1	D	H		
KTZ23.7-63	3.7	50	283	338	213	667	539	252	637	150	62
KTZ33.7-63	3.7	80	283	353	213	677	539	252	637	150	62
KTZ43.7-63	3.7	100	283	368	213	687	539	252	637	150	62