

80U23.7 -64

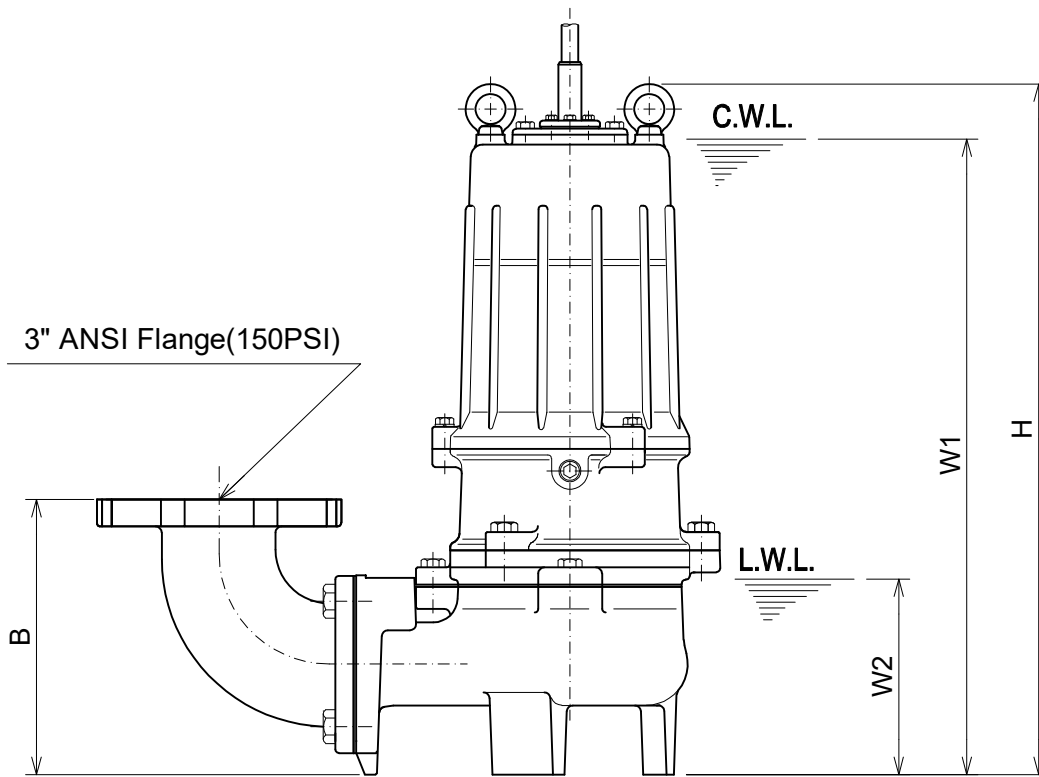
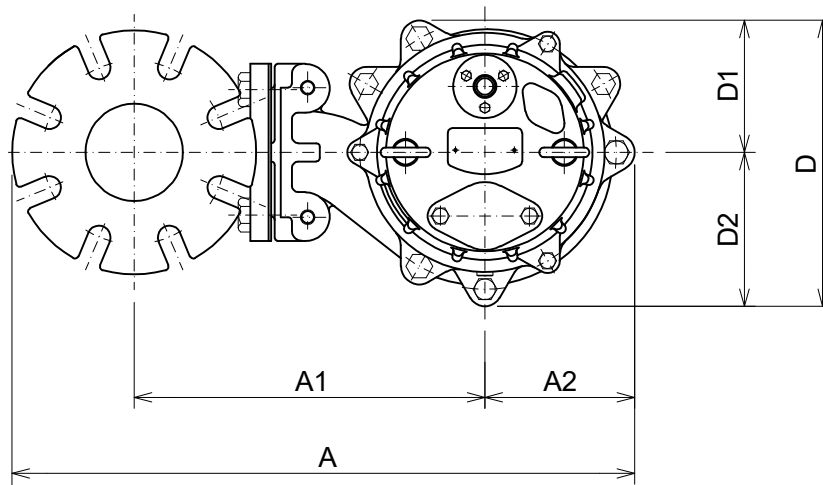

3" ANSI Flange(150PSI)

C.W.L. : Continuous running Water Level
L.W.L. : Lowest running Water Level

DIMENSIONS:USCS(Inch)

Model	HP	NOM. SIZE	Pump & Motor								C.W.L. W1	L.W.L. W2	*Wt. (lbs.)
			A	A1	A2	B	D	D1	D2	H			
80U23.7 -64	5	3"	20 1/2	11 5/16	4 13/16	8 7/8	9 3/16	4 1/4	4 15/16	22 1/4	20 1/2	6 1/4	132

*Excluding Cable.

DIMENSIONS:METRIC(mm)

Model	kW	NOM. SIZE	Pump & Motor								C.W.L. W1	L.W.L. W2	*Wt. (kg)
			A	A1	A2	B	D	D1	D2	H			
80U23.7 -64	3.7	80	520	287	123	226	234	108	126	565	520	160	60