



**C-SERIES
CUTTER - TYPE - SEWAGE & WASTEWATER PUMPS**

DIMENSIONS

80C41.5-CR -63

Bend model:
BEND80-80 ANSI

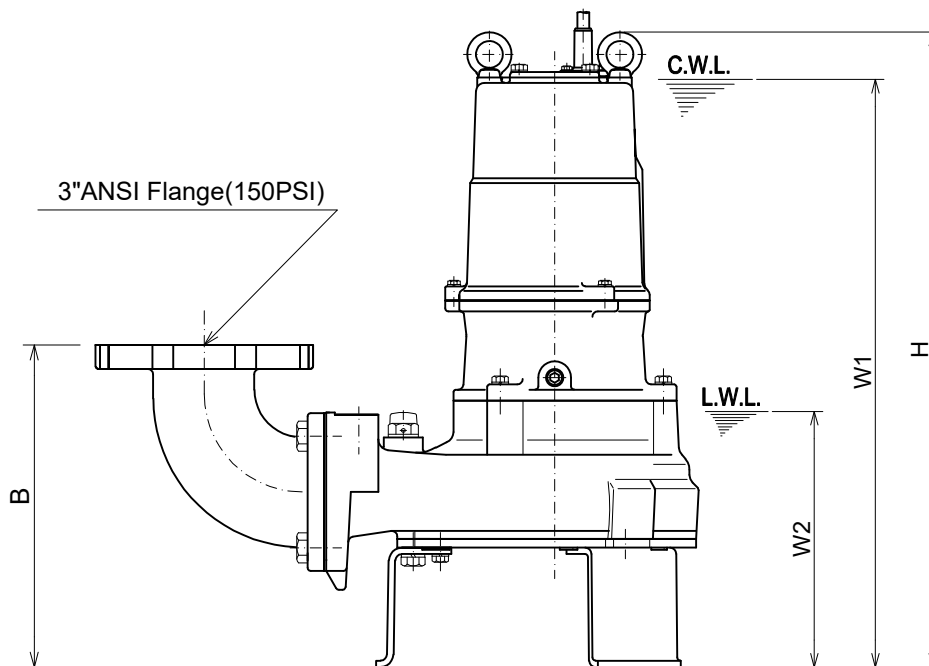
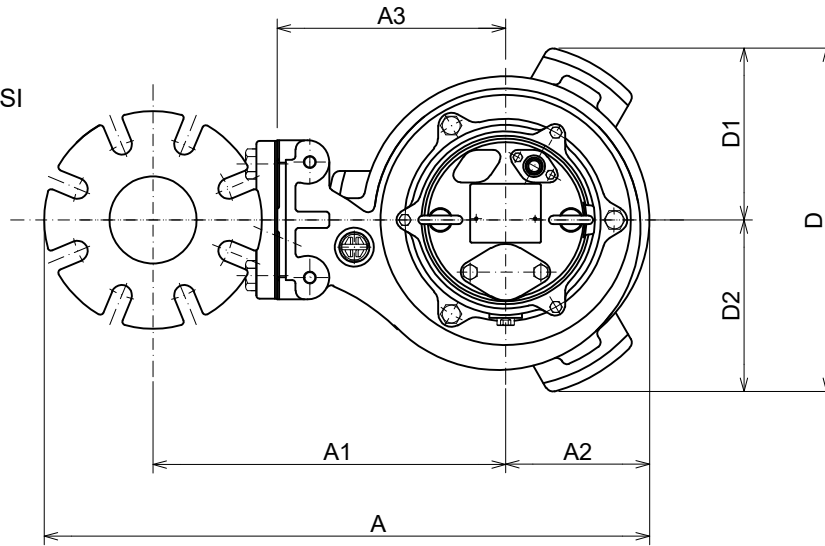

C.W.L. : Continuous running Water Level
L.W.L. : Lowest running Water Level

DIMENSIONS:USCS(Inch)

Model	HP	NOM. SIZE	Pump & Motor									C.W.L.	L.W.L.	Wt. (lbs.)
			A	A1	A2	A3	B	D	D1	D2	H			
80C41.5-CR -63	2	3"	22 1/16	13	5 3/16	8 1/4	11 5/8	12 7/16	6 1/4	6 1/4	22 5/8	20 7/8	8 7/8	126

DIMENSIONS:METRIC(mm)

Model	kW	NOM. SIZE	Pump & Motor									C.W.L.	L.W.L.	Wt. (kg)
			A	A1	A2	A3	B	D	D1	D2	H			
80C41.5-CR -63	1.5	80	561	330	132	210	296	316	158	158	574	530	225	57