

80C215-CR -61

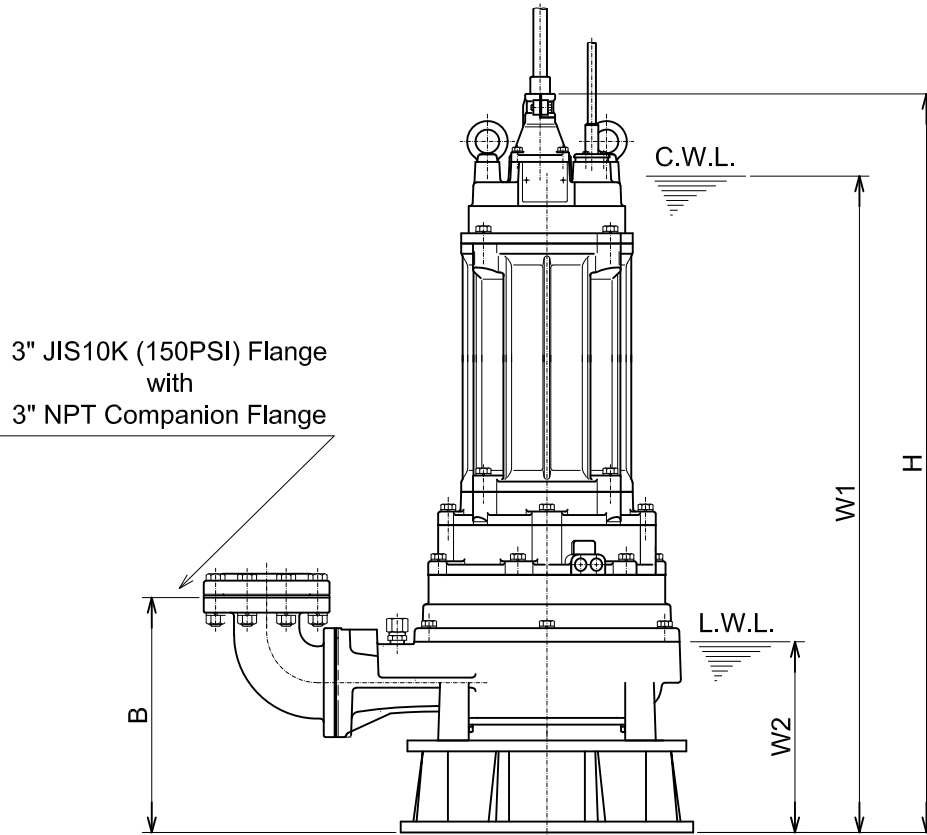
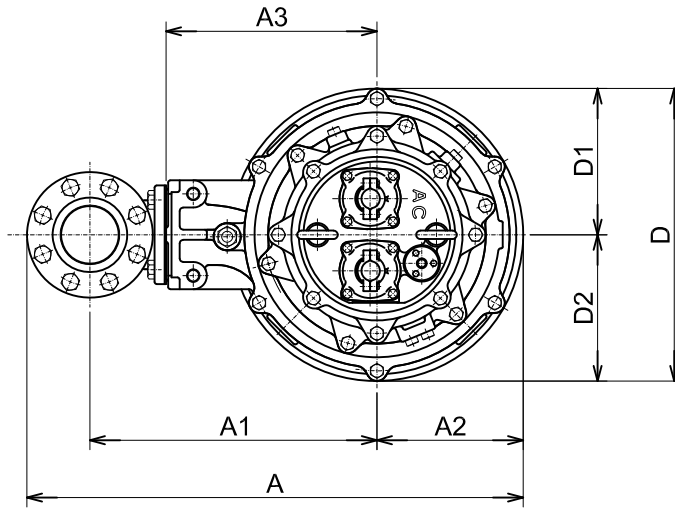

3" JIS10K (150PSI) Flange with 3" NPT Companion Flange

C.W.L. :Continuous running Water Level
L.W.L.:Lowest running Water Level

DIMENSIONS:USCS (Inch)

Model	HP	NOM. SIZE	Pump & Motor									C.W.L. W1	L.W.L. W2	*Wt. (lbs.)
			A	A1	A2	A3	B	D	D1	D2	H			
80C215-CR-61	20	3"	28 3/4	16 5/8	8 7/16	12 3/16	13 9/16	16 15/16	8 7/16	8 7/16	42 3/4	38	11	573

DIMENSIONS:METRIC (mm)

*Excluding Cable

Model	kW	NOM. SIZE	Pump & Motor									C.W.L. W1	L.W.L. W2	*Wt. (kg)
			A	A1	A2	A3	B	D	D1	D2	H			
80C215-CR-61	15	80	730	422	215	310	345	430	215	215	1086	965	280	260