

350BZ622H -61
350BZ630H -61
350BZ637H -61

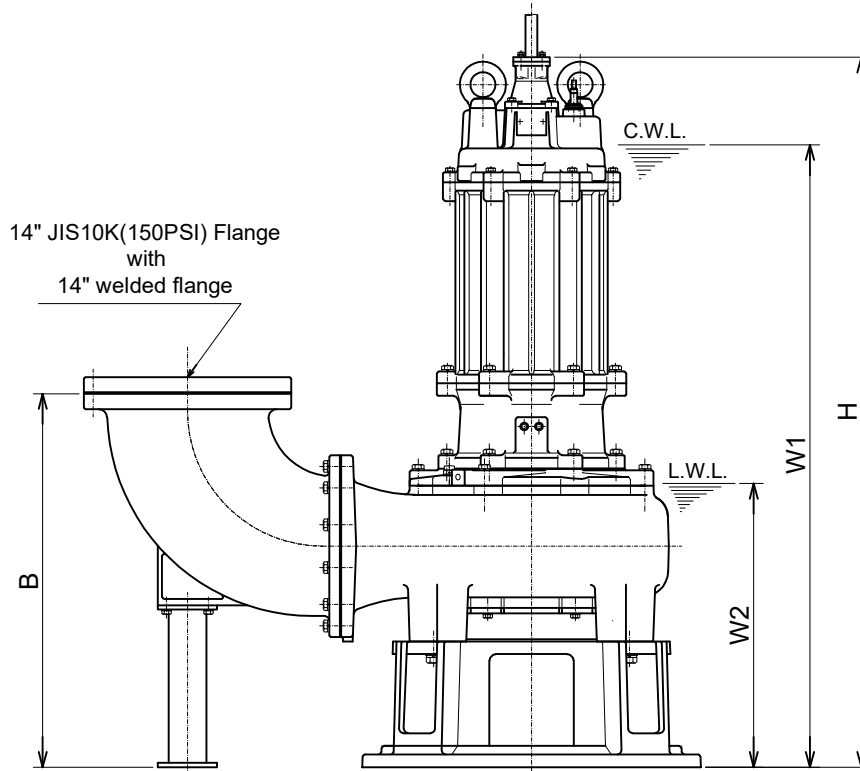

C.W.L. :Continuous running Water Level
L.W.L. :Lowest running Water Level

DIMENSIONS:USCS (Inch)

Model	HP	NOM. SIZE	Pump & Motor									C.W.L.	L.W.L.	*Wt. (lbs.)
			A	A1	A2	A3	B	D	D1	D2	H			
350BZ622H-61	30	14"	59 3/8	34	15 3/4	17 11/16	34 13/16	31 1/2	15 3/4	15 3/4	66	57 7/8	26 3/8	2010
350BZ630H-61	40	14"	59 3/8	34	15 3/4	17 11/16	34 13/16	31 1/2	15 3/4	15 3/4	66	57 7/8	26 3/8	2090
350BZ637H-61	50	14"	59 3/8	34	15 3/4	17 11/16	34 13/16	31 1/2	15 3/4	15 3/4	66	57 7/8	26 3/8	2070

DIMENSIONS:METRIC (mm)

*Excluding Cable

Model	kW	NOM. SIZE	Pump & Motor									C.W.L.	L.W.L.	*Wt. (kg)
			A	A1	A2	A3	B	D	D1	D2	H			
350BZ622H-61	22	350	1508	863	400	450	885	800	400	400	1677	1470	670	910
350BZ630H-61	30	350	1508	863	400	450	885	800	400	400	1677	1470	670	950
350BZ637H-61	37	350	1508	863	400	450	885	800	400	400	1677	1470	670	940