

300BZ455H -61
300BZ475H -61

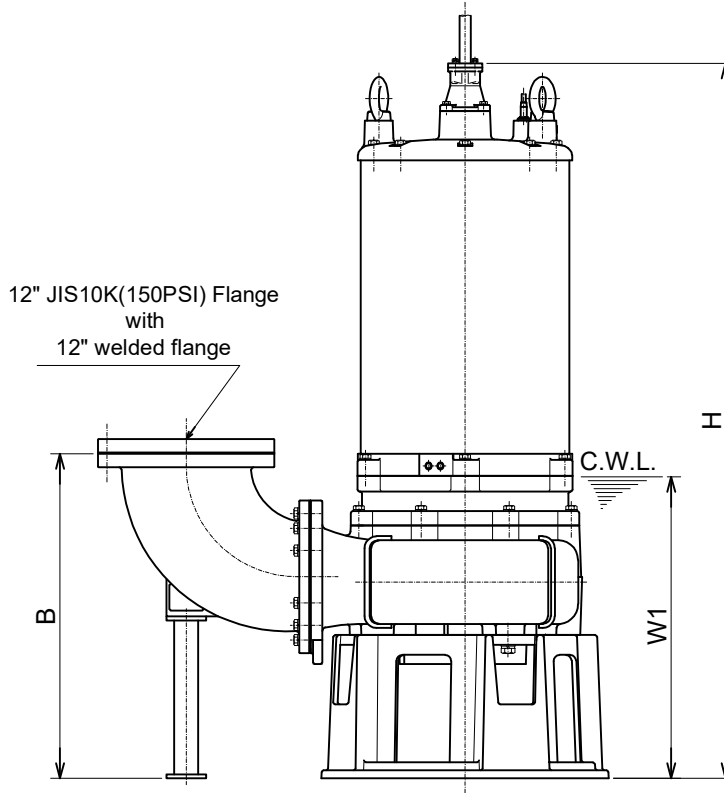
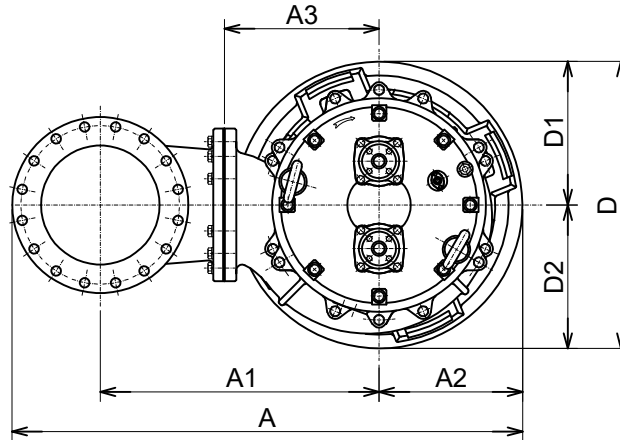

C.W.L. :Continuous running Water Level

DIMENSIONS:USCS (Inch)

| Model | HP | NOM. SIZE | Pump & Motor | | | | | | | | C.W.L. W1 | *Wt. (lbs.) | |
|--------------|-----|-----------|--------------|----------|--------|--------|---------|--------|--------|--------|-----------|-------------|------|
| | | | A | A1 | A2 | A3 | B | D | D1 | D2 | | | H |
| 300BZ455H-61 | 75 | 12" | 50 11/16 | 27 11/16 | 14 1/4 | 15 3/8 | 32 3/16 | 28 1/2 | 14 1/4 | 14 1/4 | 70 15/16 | 29 7/8 | 3060 |
| 300BZ475H-61 | 100 | 12" | 50 11/16 | 27 11/16 | 14 1/4 | 15 3/8 | 32 3/16 | 28 1/2 | 14 1/4 | 14 1/4 | 70 15/16 | 29 7/8 | 3060 |

DIMENSIONS:METRIC (mm)

*Excluding Cable

| Model | kW | NOM. SIZE | Pump & Motor | | | | | | | | C.W.L. W1 | *Wt. (kg) | |
|--------------|----|-----------|--------------|-----|-----|-----|-----|-----|-----|-----|-----------|-----------|------|
| | | | A | A1 | A2 | A3 | B | D | D1 | D2 | | | H |
| 300BZ455H-61 | 55 | 300 | 1288 | 703 | 362 | 390 | 818 | 724 | 362 | 362 | 1802 | 760 | 1390 |
| 300BZ475H-61 | 75 | 300 | 1288 | 703 | 362 | 390 | 818 | 724 | 362 | 362 | 1802 | 760 | 1390 |