

250BZ622 -61
250BZ437 -61
250BZ445 -61

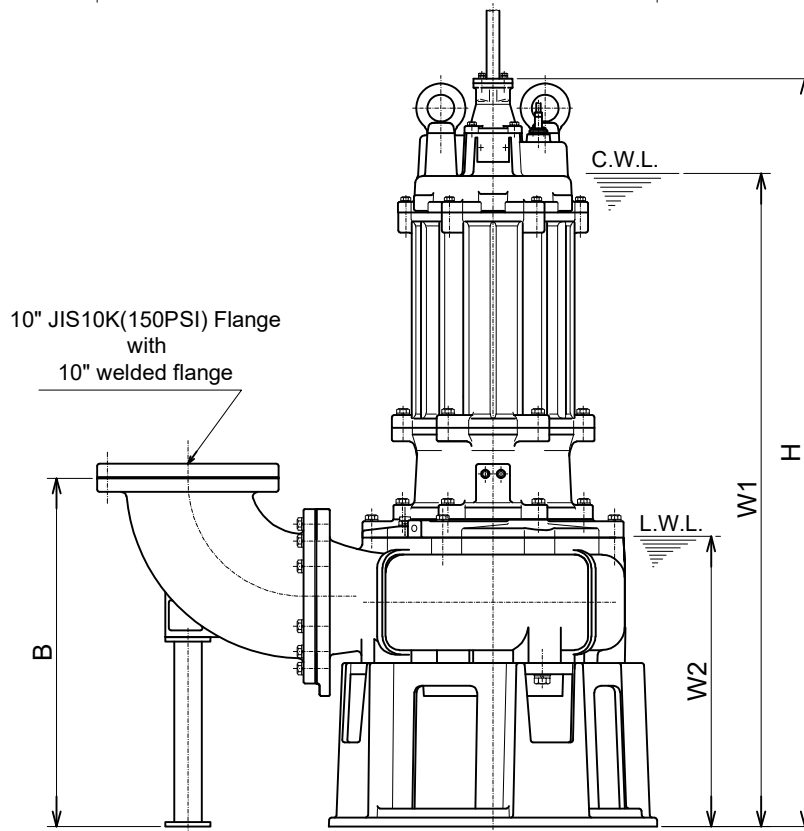

C.W.L. :Continuous running Water Level
L.W.L. :Lowest running Water Level

DIMENSIONS:USCS (Inch)

Model	HP	NOM. SIZE	Pump & Motor									C.W.L.	L.W.L.	*Wt. (lbs.)
			A	A1	A2	A3	B	D	D1	D2	H			
250BZ622-61	30	10"	48 5/8	26 1/2	14 1/4	15 3/8	30 1/4	28 1/2	14 1/4	14 1/4	64 15/16	56 3/4	25 1/4	1790
250BZ437-61	50	10"	48 5/8	26 1/2	14 1/4	15 3/8	30 1/4	28 1/2	14 1/4	14 1/4	64 1/2	56 1/4	25 1/4	1940
250BZ445-61	60	10"	48 5/8	26 1/2	14 1/4	15 3/8	30 1/4	28 1/2	14 1/4	14 1/4	64 15/16	56 3/4	25 1/4	1960

DIMENSIONS:METRIC (mm)

*Excluding Cable

Model	kW	NOM. SIZE	Pump & Motor									C.W.L.	L.W.L.	*Wt. (kg)
			A	A1	A2	A3	B	D	D1	D2	H			
250BZ622-61	22	250	1235	673	362	390	768	724	362	362	1650	1440	640	810
250BZ437-61	37	250	1235	673	362	390	768	724	362	362	1638	1430	640	880
250BZ445-61	45	250	1235	673	362	390	768	724	362	362	1650	1440	640	890