

250BZ430 -61

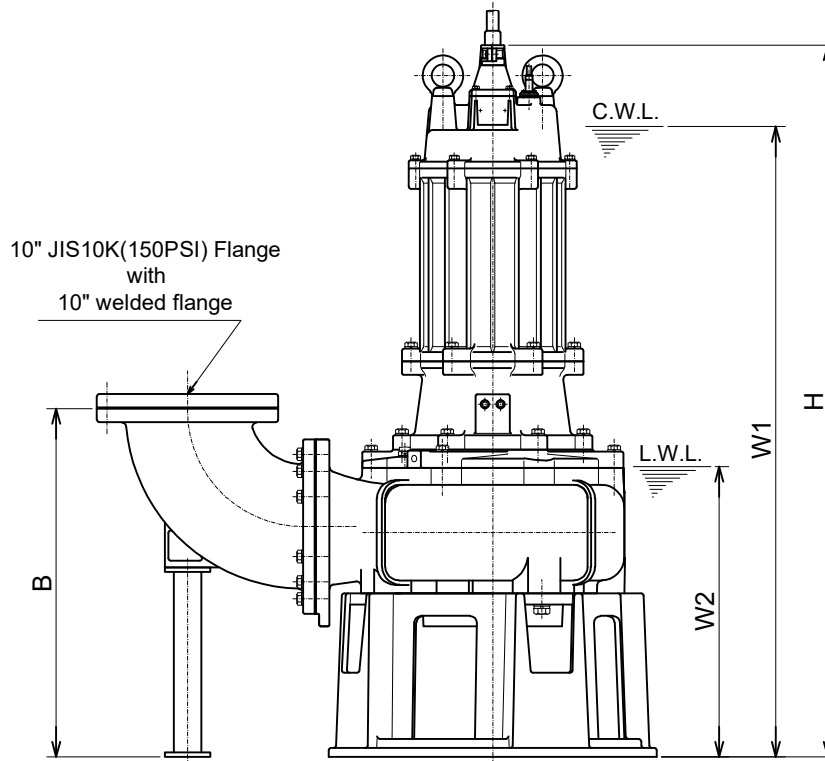
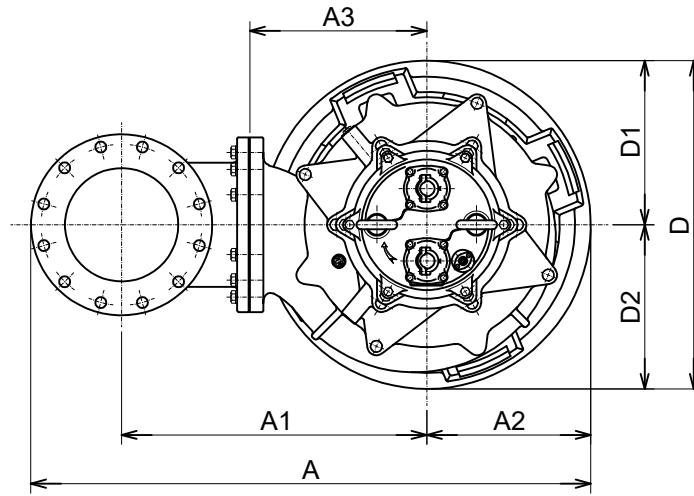

C.W.L. :Continuous running Water Level
L.W.L. :Lowest running Water Level

DIMENSIONS:USCS (Inch)

Model	HP	NOM. SIZE	Pump & Motor									C.W.L.	L.W.L.	*Wt. (lbs.)
			A	A1	A2	A3	B	D	D1	D2	H			
250BZ430-61	40	10"	48 5/8	26 1/2	14 1/4	15 3/8	30 1/4	28 1/2	14 1/4	14 1/4	61 13/16	54 3/4	25 1/4	1830

DIMENSIONS:METRIC (mm)

Model	kW	NOM. SIZE	Pump & Motor									C.W.L.	L.W.L.	*Wt. (kg)
			A	A1	A2	A3	B	D	D1	D2	H			
250BZ430-61	30	250	1235	673	362	390	768	724	362	362	1570	1390	640	830

*Excluding Cable